

FLAT VENEER PANEL CEILING AND WALL SYSTEMS
ARCHITECTURAL SPECIFICATIONS

PART 1 - GENERAL

- A. The Flat Veneer Panel Ceiling and Wall Systems covered by this specification shall be the products of the Rulon International, World Commerce Center, 2000 Ring Way Road, St. Augustine, FL 32092. Phone: 800-227-8566, 904-584-1400, Fax: 904-584-1499, www.rulonco.com.
- B. The General Conditions and the requirements of Division 1 of the Specifications shall apply to all work hereunder.
- C. All work shall be performed in accordance with the manufacturer's instructions, and in a manner satisfactory to the owner's representative.

1.01 SCOPE

- A. Rulon International shall furnish all Flat Veneer Panels and specified matching trims. The suspension system shall be in accordance with drawings, and supplied by others.

1.02 RELATED WORK NOT INCLUDED UNDER THIS SECTION

- A. Suspension systems and components for ceilings other than manufacturer's Flat Veneer Panel Ceiling Systems shall not be included.

1.03 QUALITY ASSURANCE

- A. Installer Qualifications: Installer shall be a firm with not less than two (2) years of successful experience in installation of suspended wood ceilings of similar requirements to this project. The installer shall be acceptable to the architect, manufacturer, and owner's representative.
- B. Fire Performance Characteristics: When specified as "Fire Resistant", Rulon Flat Veneer Panels shall conform to Class 1, or A flame spread rating, when tested according to ASTM E-84.
- C. Environmental Standards: When required, veneer panel components shall originate from well managed forests as certified by accredited and recognized industry certifying organizations.

1.04 PROJECT CONDITIONS

- A. Installation shall be done only when the temperature and humidity closely approximate the interior conditions that will exist when the building is occupied. The heating and cooling systems shall be operating before, during, and after installation, with the humidity of the interior spaces maintained between 25% and 55%, temperature between 60 to 90 degrees F.
- B. It is important that plenums have proper ventilation, especially in high moisture areas. There shall be no excessive build up of heat in the ceiling areas.
- C. Prior to the start of installation, all exterior windows and doors are to be in place, glazed, and weather-stripped. The roof is to be watertight, and all wet trades' work is to be completed, and thoroughly dry.
- D. Mechanical, electrical, and other utility service installations above the ceiling plane shall have been completed. No materials should rest against, or wrap around, the ceiling suspension components or connecting hangers.

1.05 COORDINATION OF WORK

- A. The layout and installation of the Flat Veneer Panel Suspended Ceiling System and suspension components shall be coordinated with other work penetrating the ceiling. This includes light fixtures, HVAC equipment, and fire suppression system components.

1.06 SUBMITTALS

- A. Product Data: Rulon International shall provide product specifications for all ceiling materials supplied.
- B. Shop Drawings: When required, Rulon International shall supply shop drawings showing Flat Veneer Panel locations, and placement of hangers, carriers, and other details deemed pertinent to proper installation.
- C. Samples: A wood sample with designated finishes shall be submitted for approval.

1.07 DELIVERY, STORAGE, AND HANDLING

- A. The Flat Veneer Panels shall be delivered to the project site in original, unopened packages.
- B. The Flat Veneer Panels shall be stored flat and level in a fully enclosed space. For a minimum of seventy-two (72) hours immediately prior to ceiling installation, the Flat Veneer Panels shall be stored in the room in which they will be installed. The temperature and humidity of the room shall closely approximate those conditions that will exist when the building is occupied. The Flat Veneer Panels shall be stored off the floor.

- C. Care in handling must be exercised to avoid damage.

1.08 WARRANTIES

- A. Manufacturer: All materials supplied by the ceiling manufacturer shall be guaranteed against manufacturing defects for one (1) year. Because of differing site conditions, wood stains and colorings can vary with age and shall be excluded from this warranty.
- B. Contractor: All work shall be guaranteed for one (1) year from final acceptance of completed work

PART 2 - PRODUCTS

2.01 FLAT VENEER PANELS

- A. The Flat Veneer Panels shall be manufactured by Rulon International, St. Augustine, Florida, PH-1-800-227-8566, 904-584-1400, Panels shall be factory-fabricated to sizes established by approved Rulon shop drawings and confirmed by field dimensions. The Rulon Flat Veneer Panels will be made with a [veneer species] face veneer, [veneer cut] [veneer match], applied to a 3/4" (19mm) thick core material. Wood is a natural product that will undergo changes with variations in the environment. Therefore, all dimension tolerances shall be $\pm 1/8"$ (3mm).

2.02 SUSPENSION SYSTEM

- A. Ceiling panels shall be suspended from standard heavy duty 15/16" (24mm) T-rail (supplied by contractor) using torsion springs, C-hangers, or direct screw attachment, according to project design.
- B. Wall panels shall be attached to the structure using Rulon-supplied Z-clips. The panels shall be prevented from moving laterally by blocking or other such methods.

2.03 EDGES, BORDERS, AND PERIMETER TRIMS

- A. Edges, borders, and perimeter trims, shall be designated by specifier in accordance with standard design details available. All wood products specified shall be supplied by the ceiling manufacturer.

2.04 FINISHES AND COLORS

- A. The Flat Veneer Panel face and edge surfaces shall be factory finished with a clear or custom stain as selected by the Architect. A clear finish is applied to the back side of panels. Wood is a natural product with variations in grain, texture and color – often ranging from light to dark – thereby affecting the surface look. Product finishes shall be stain or sealer coats – spray applied to a smooth sanded surface.

PART 3 - EXECUTION

3.01 PREPARATION

- A. Ceiling Layout: The contractor shall measure ceiling areas and establish layout of hangers and T-rails, in accordance with installation instructions.
- B. Coordination: The contractor shall furnish the layout for supports that shall be installed for suspension of ceilings. He shall furnish concrete inserts, steel deck hanger clips, or similar devices for installation, in time to coordinate the work. The contractor shall coordinate with other trades the location of devices which will penetrate the Ceiling Panels or interfere with the installation. Recessed or surface devices located within the ceiling panels are to be located and cut in the field.

3.02 INSTALLATION

- A. General: The contractor shall install materials in accordance with Rulon International printed instructions and architect's drawings. The installation shall comply with applicable regulations and industry standards.

3.03 ADJUSTMENT CLEANING AND REPAIR

- A. The contractor shall make final adjustment to level or contours.
- B. Upon completion of ceiling installation, all Flat Veneer Panels shall be cleaned free of dirt, dust, grease, oils, and fingerprints.
- C. All work which cannot be successfully cleaned and repaired shall be removed and replaced.

3.04 INSPECTION

- A. Upon the completion of ceiling installation, the owner's representative shall inspect all finished surfaces to ensure that work was performed in a manner satisfactory to the owner. Any deficiencies in the installed ceiling shall be corrected by the contractor at no additional cost to the owner or to panel manufacturer.

<u>DRAWING #</u>	<u>TITLE</u>
AXXX0011	C-Hanger Mounting Detail
AXXX0012	Torsion Spring Mounting Detail - Flush
AXXX0013	Z-Clip Mounting Detail
AXXX0014	Side Spline Detail
AXXX0015	Direct ScREW Ceiling Attachment Detail
AXXX0016	Edge Conditions Details

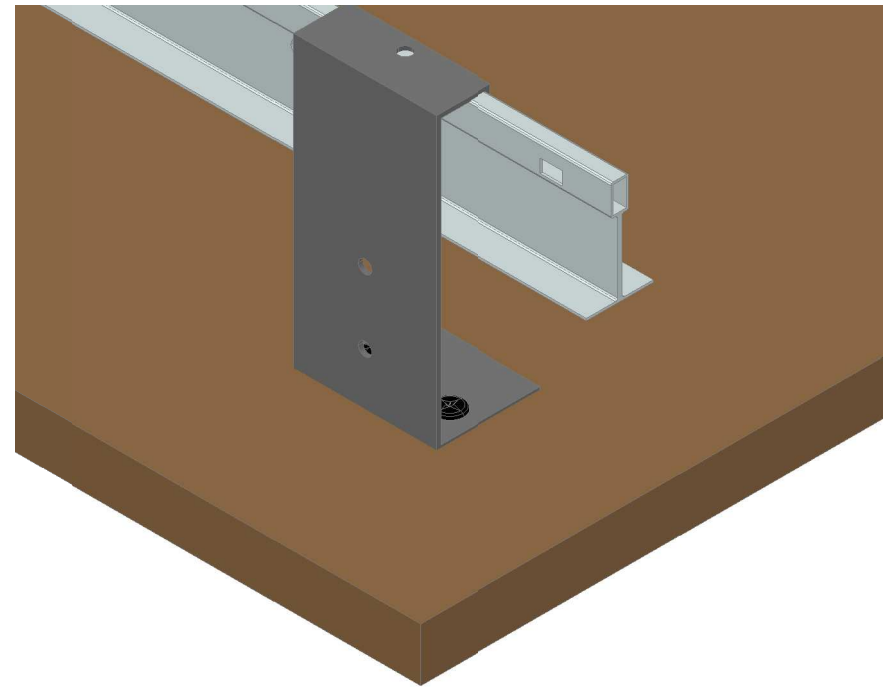

Flat Veneer Panel with C-Hanger

 RULON INTERNATIONAL	World Commerce Center 2000 Ring Way Road St. Augustine, FL 32092 Ph: 1-800-227-8566 904-584-1400 Fax: 904-584-1499 www.rulonco.com info@rulonco.com	PROJECT: TITLE: Flat Veneer Panel Index	ISSUE DATE: REVISION DATE: SEP/14/2012	DRAWN BY: CAP CHECKED BY: TA	PROJECT NUMBER: DRAWING NUMBER: F00INDEX

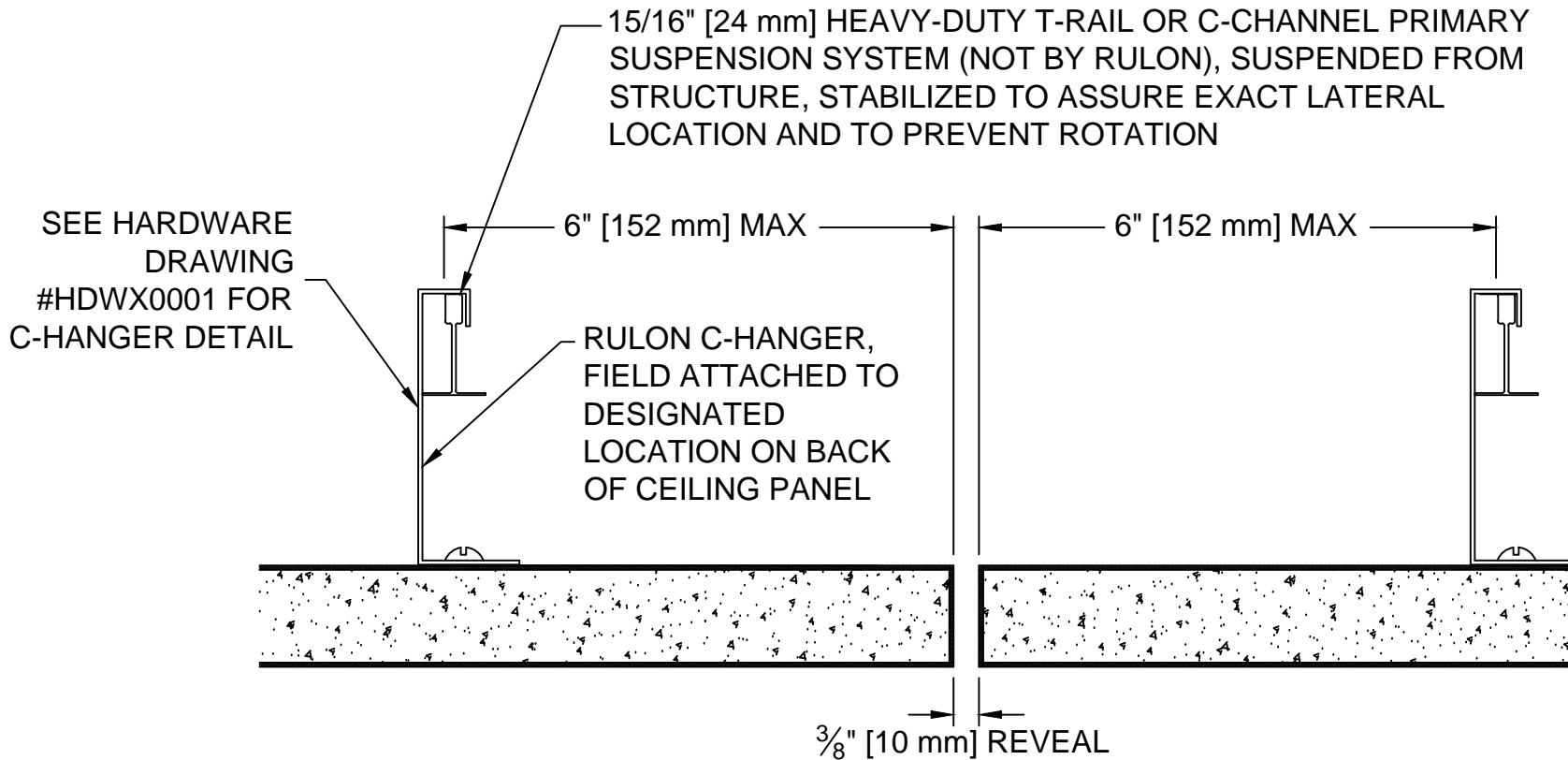

RULON INTERNATIONAL

World Commerce Center
 2000 Ring Way Road
 St. Augustine, FL 32092
 Ph: 1-800-227-8566
 904-584-1400
 Fax: 904-584-1499
 www.rulonco.com
 info@rulonco.com

PROJECT:

TITLE:

C-Hanger Mounting Detail

ISSUE DATE:

REVISION DATE:

SEP/13/2012

DRAWN BY:

CAP

CHECKED BY:

TA

PROJECT NUMBER:

DRAWING NUMBER:

AXXX0011

NOTE:
SEE HARDWARE DRAWING
#HDWX002 FOR TORSION
SPRING ASSEMBLY DETAIL

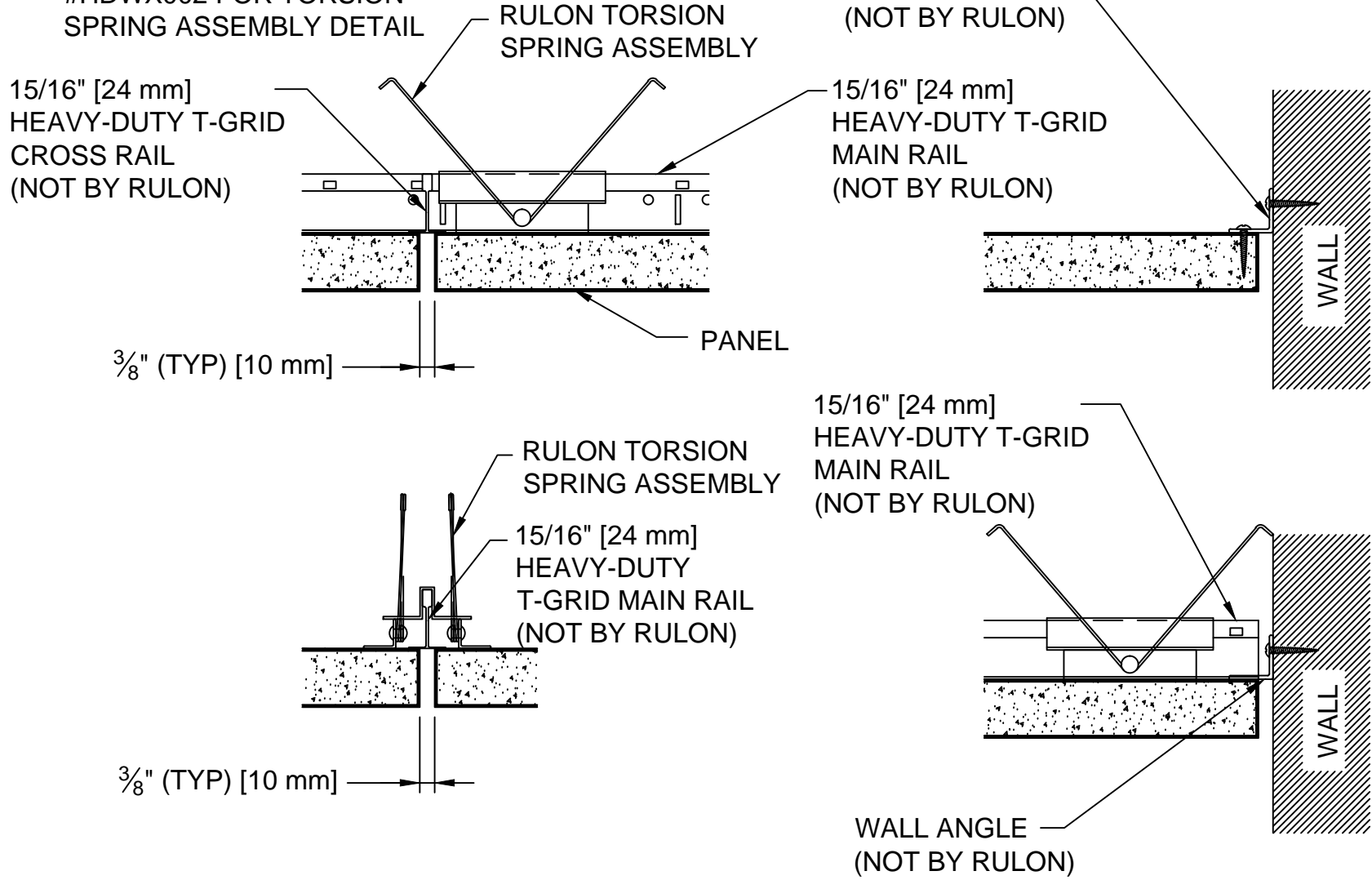

RULON INTERNATIONAL

World Commerce Center
2000 Ring Way Road
St. Augustine, FL 32092
Ph: 1-800-227-8566
904-584-1400
Fax: 904-584-1499
www.rulonco.com
info@rulonco.com

PROJECT:

TITLE: **Torsion Spring Mounting Detail -
Flush**

ISSUE DATE:

REVISION DATE:
SEP/13/2012

DRAWN BY:

CAP

CHECKED BY:

TA

PROJECT NUMBER:

DRAWING NUMBER:

AXXX0012

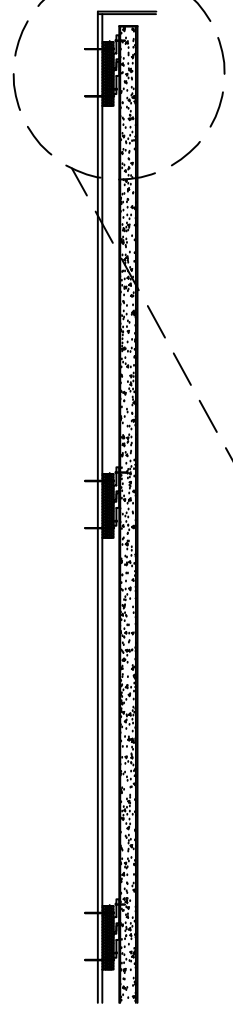

MATCHING
VENEER
EDGE BAND

RULON Z-CLIPS
FIELD INSTALLED

BLOCKING AS
NECESSARY
(BY OTHERS)

BALANCING
VENEER ON
BACK

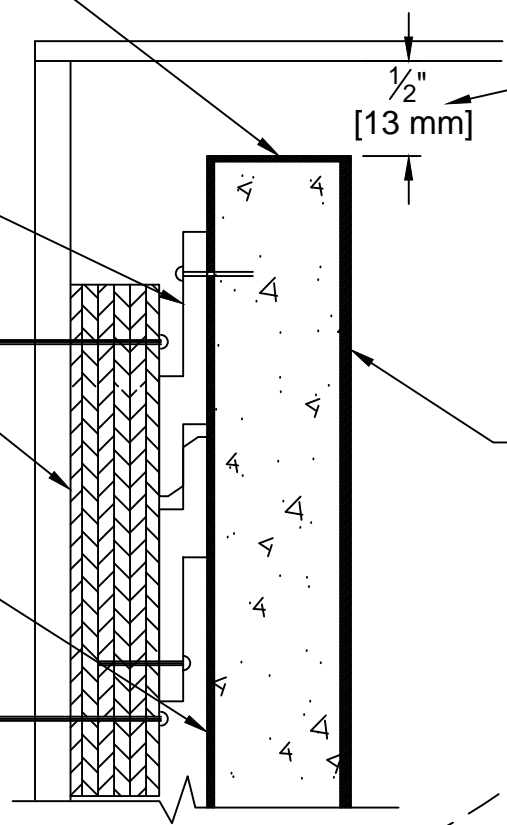

REQUIRED SPACE
TO INSTALL
PANELS (LIFT
PANEL AND
ENGAGE ONTO
Z-CLIPS)

RULON PANEL
FACE

NOTE:
SEE HARDWARE
DRAWING #HDWX0003
FOR Z-CLIP DETAIL



RULON INTERNATIONAL

World Commerce Center
2000 Ring Way Road
St. Augustine, FL 32092
Ph: 1-800-227-8566
904-584-1400
Fax: 904-584-1499
www.rulonco.com
info@rulonco.com

PROJECT:

TITLE: **Z-Clip Mounting Detail**

ISSUE DATE:

REVISION DATE:
SEP/13/2012

DRAWN BY:
CAP

CHECKED BY:
TA

PROJECT NUMBER:

DRAWING NUMBER:
AXXX0013

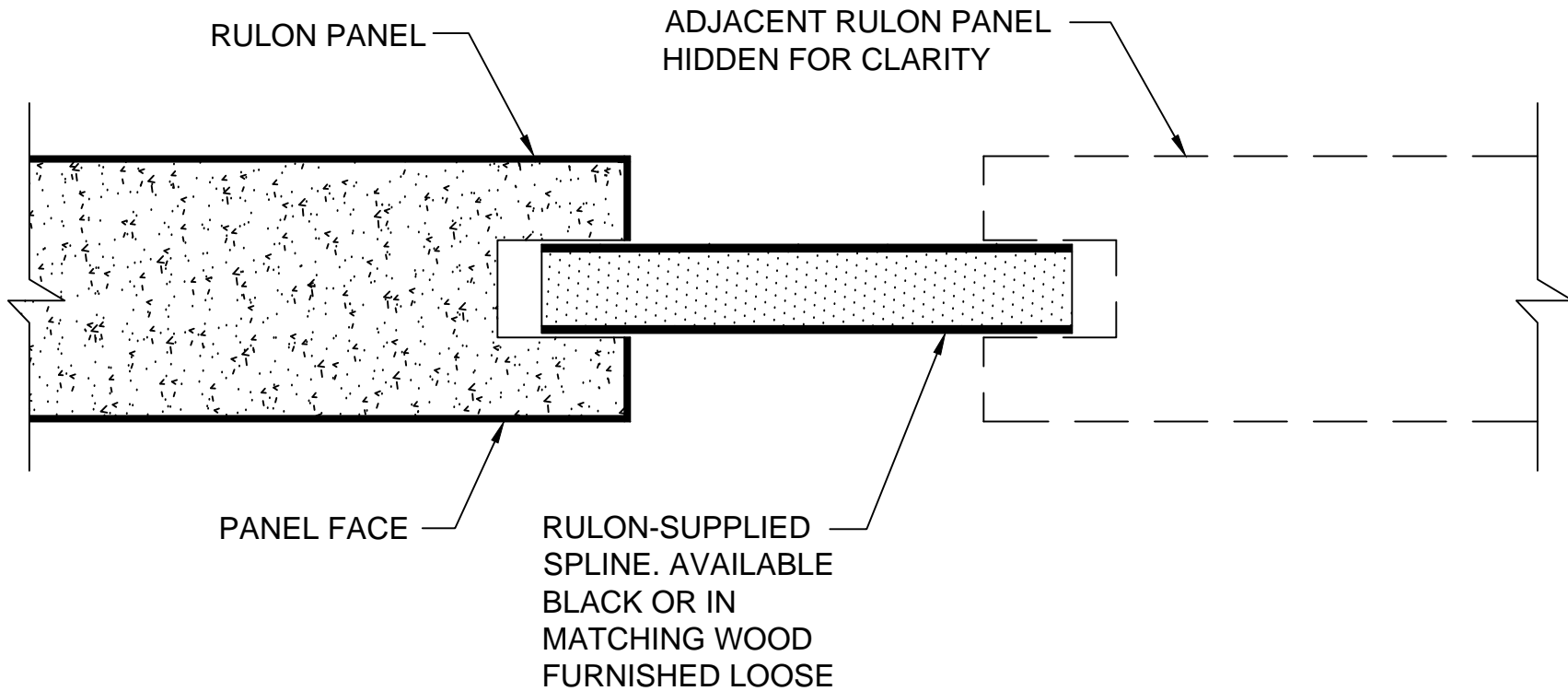

RULON INTERNATIONAL

World Commerce Center
 2000 Ring Way Road
 St. Augustine, FL 32092
 Ph: 1-800-227-8566
 904-584-1400
 Fax: 904-584-1499
 www.rulonco.com
 info@rulonco.com

PROJECT:

TITLE: **Side Spline Detail**

ISSUE DATE:

REVISION DATE:
SEP/13/2012

DRAWN BY:
CAP



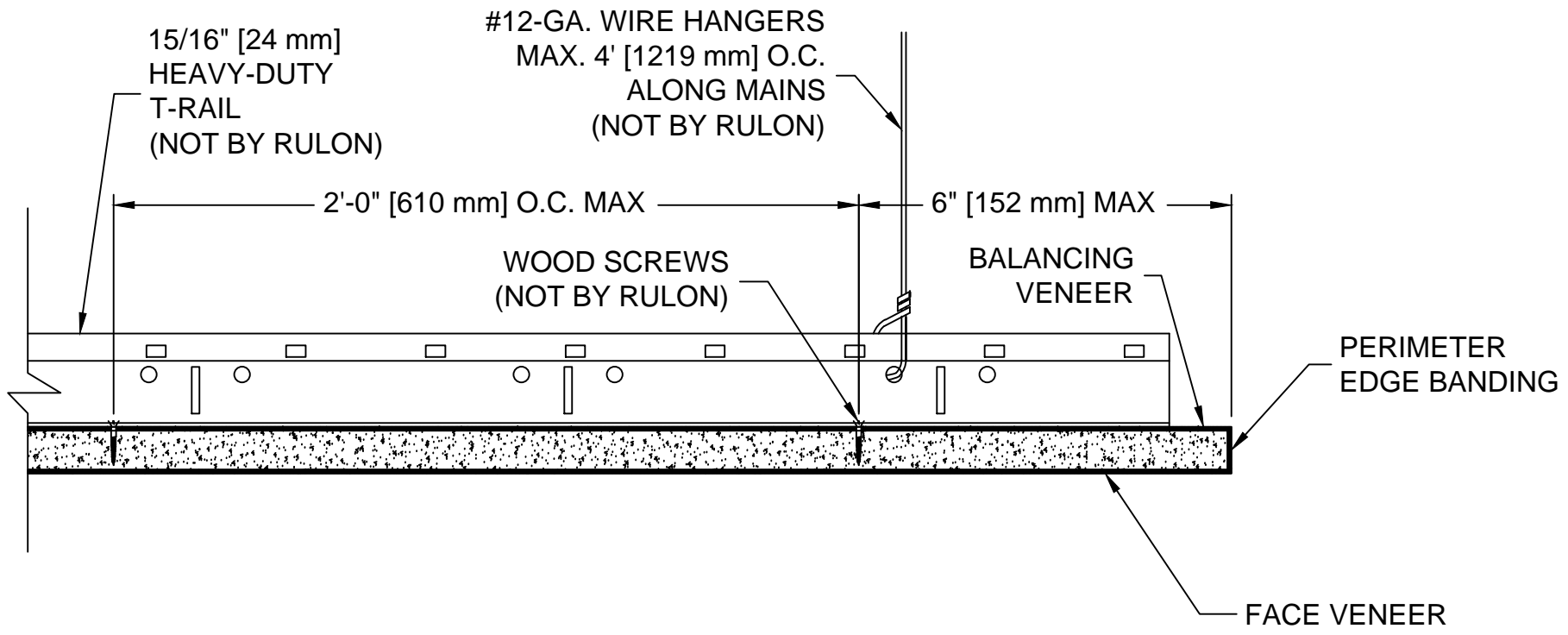

CHECKED BY:
TA

PROJECT NUMBER:

DRAWING NUMBER:
AXXX0014

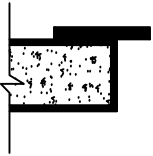
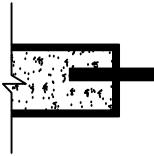

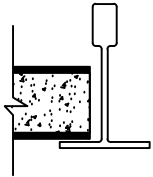
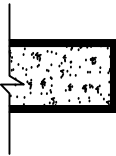
 <p>RULON INTERNATIONAL</p>	World Commerce Center 2000 Ring Way Road St. Augustine, FL 32092 Ph: 1-800-227-8566 904-584-1400 Fax: 904-584-1499 www.rulonco.com info@rulonco.com	PROJECT: TITLE: Direct Screw Ceiling Attachment Detail	ISSUE DATE: REVISION DATE: SEP/13/2012	DRAWN BY: CAP CHECKED BY: TA	PROJECT NUMBER: DRAWING NUMBER: AXXX0015

<p>Edge-banded Full Depth Tegular</p>	<p>Edge-banded Partial Depth Tegular</p>	<p>Standard Tegular</p>	<p>Lay-in</p>
 <p>Available for Ceilings: 15/16" [24 mm] Grid and 9/16" [14 mm] Grid</p>	 <p>Available for Ceilings: 15/16" [24 mm] GRID AND 9/16" [14 mm] GRID</p>	 <p>Available for Ceilings: 15/16" [24 mm] GRID AND 9/16" [14 mm] GRID</p>	 <p>Available for Ceilings: 15/16" [24 mm] GRID AND 9/16" [14 mm] GRID</p>
<p>Edge-banded</p>	<p>Edge-banded Side Slot</p>	<p>Edge-banded Side Spline</p>	<p>NOTES:</p> <p>1) Heavy Duty Grid Mains to be on Maximum 2' Centers</p> <p>2) These edge conditions apply to 3/4" [19 mm] Thick Panels only</p>
 <p>Available for: Walls and Ceilings (Direct attach, z-clips, C-Hangers, Torsion Springs, etc.)</p>	 <p>Available for Ceilings: 15/16" [24 mm] Grid</p>	 <p>Available for Walls: Accepts Black or Matching Wood Veneer Spline Spacer</p>	

 <p>RULON INTERNATIONAL</p> <p>World Commerce Center 2000 Ring Way Road St. Augustine, FL 32092 Ph: 1-800-227-8566 904-584-1400 Fax: 904-584-1499 www.rulonco.com info@rulonco.com</p>	<p>PROJECT:</p>	<p>ISSUE DATE:</p>	<p>DRAWN BY: CAP</p>	<p>PROJECT NUMBER:</p>
	<p>TITLE: Edge Conditions Details</p>	<p>REVISION DATE: NOV/05/2014</p>	<p>CHECKED BY: TDA</p>	<p>DRAWING NUMBER: AXXX0016</p>