

<u>DRAWING #</u>	<u>TITLE</u>
P9000001	ENDURE #900 Profile
P9000002	ENDURE #870 Perimeter Trim
P9000022	ENDURE #872 Floating 4" Trim
PXX00003	ENDURE #890 Carrier Connector
P8500004	ENDURE #850S Splice Material
P9000005	ENDURE #875 Expansion Joint
P9000006	ENDURE 900 Installation - Spacing
P9000008	ENDURE Recessed Can Light Detail
P9000009	ENDURE Linear Light Fixture
P9000010	ENDURE Access Panel Detail
PXX00012	ENDURE Direct Mount Detail

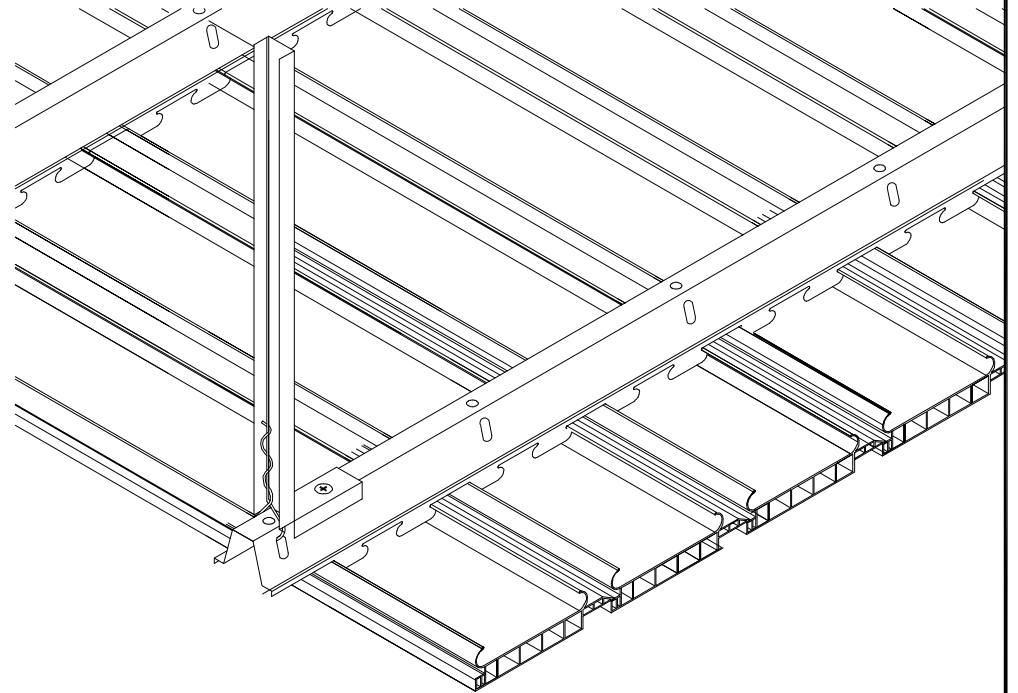

RULON INTERNATIONAL  
2000 Ring Way  
St. Augustine, FL 32092

(904) 584-1400  
info @ rulonco.com

www.rulonco.com

PROJECT:

TITLE: **ENDURE 900 Index  
4 Inch Module**

ISSUE DATE:

REVISION DATE:  
**DEC/15/2025**

DRAWN BY:

**CAP**

CHECKED BY:

**CMP**

PROJECT NUMBER:

DRAWING NUMBER:

**P900-INDEX**

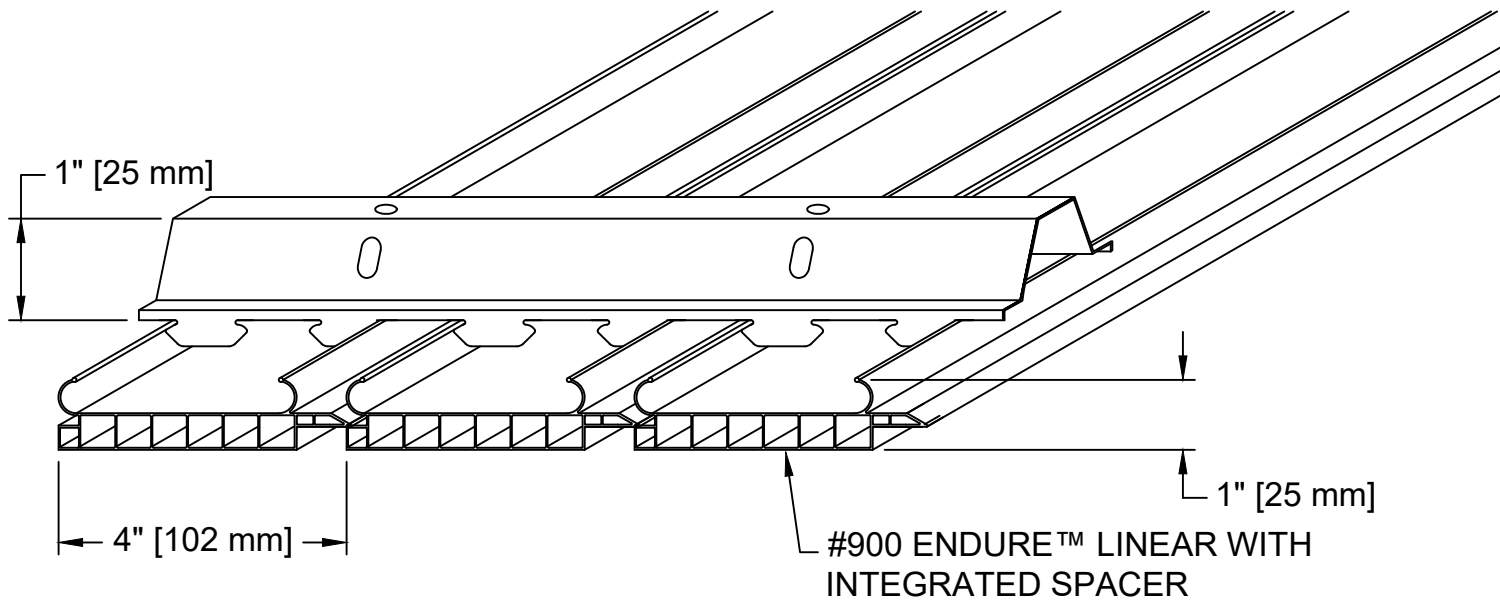

RULON INTERNATIONAL  
 2000 Ring Way  
 St. Augustine, FL 32092

(904) 584-1400  
 info @ rulonco.com

www.rulonco.com

PROJECT:

TITLE: ENDURE™ LINEAR #900 Profile

ISSUE DATE:

REVISION DATE:  
 MAR/14/2019

DRAWN BY:

CAP

CHECKED BY:

TR

PROJECT NUMBER:

DRAWING NUMBER:

P9000001

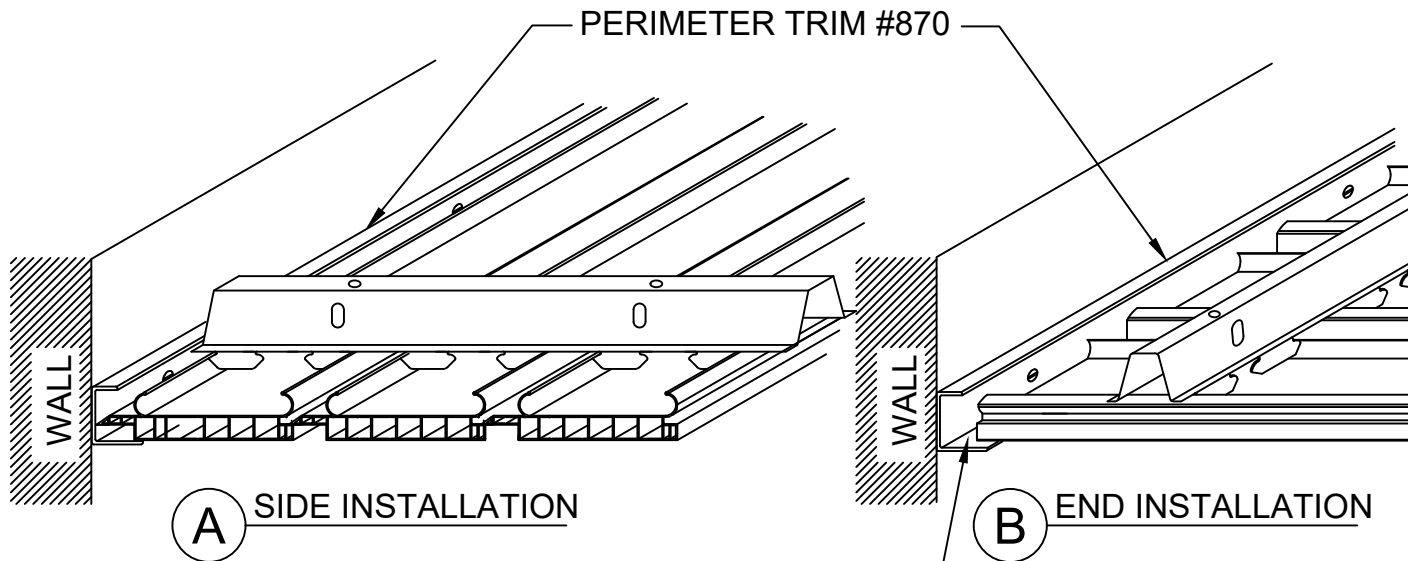

NOTE:  
 ALLOW SUFFICIENT SPACE FOR EXPANSION  
 AT PERIMETER. SEE INSTALLATION GUIDE  
 FOR MORE INFORMATION

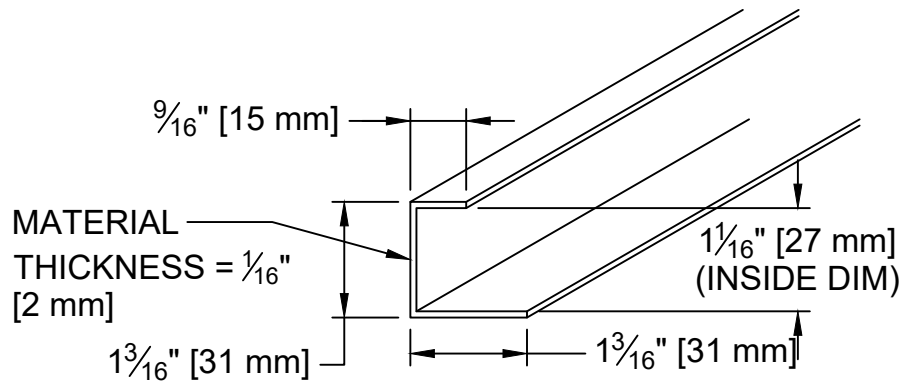

**C** #870 PERIMETER TRIM CROSS-SECTION



RULON INTERNATIONAL  
 2000 Ring Way  
 St. Augustine, FL 32092

(904) 584-1400  
 info @ rulonco.com

www.rulonco.com

PROJECT:

TITLE: ENDURE™ #870 Perimeter Trim

ISSUE DATE:

REVISION DATE:  
 OCT/13/2023

DRAWN BY:

CP

CHECKED BY:

TDA

PROJECT NUMBER:

DRAWING NUMBER:

P9000002

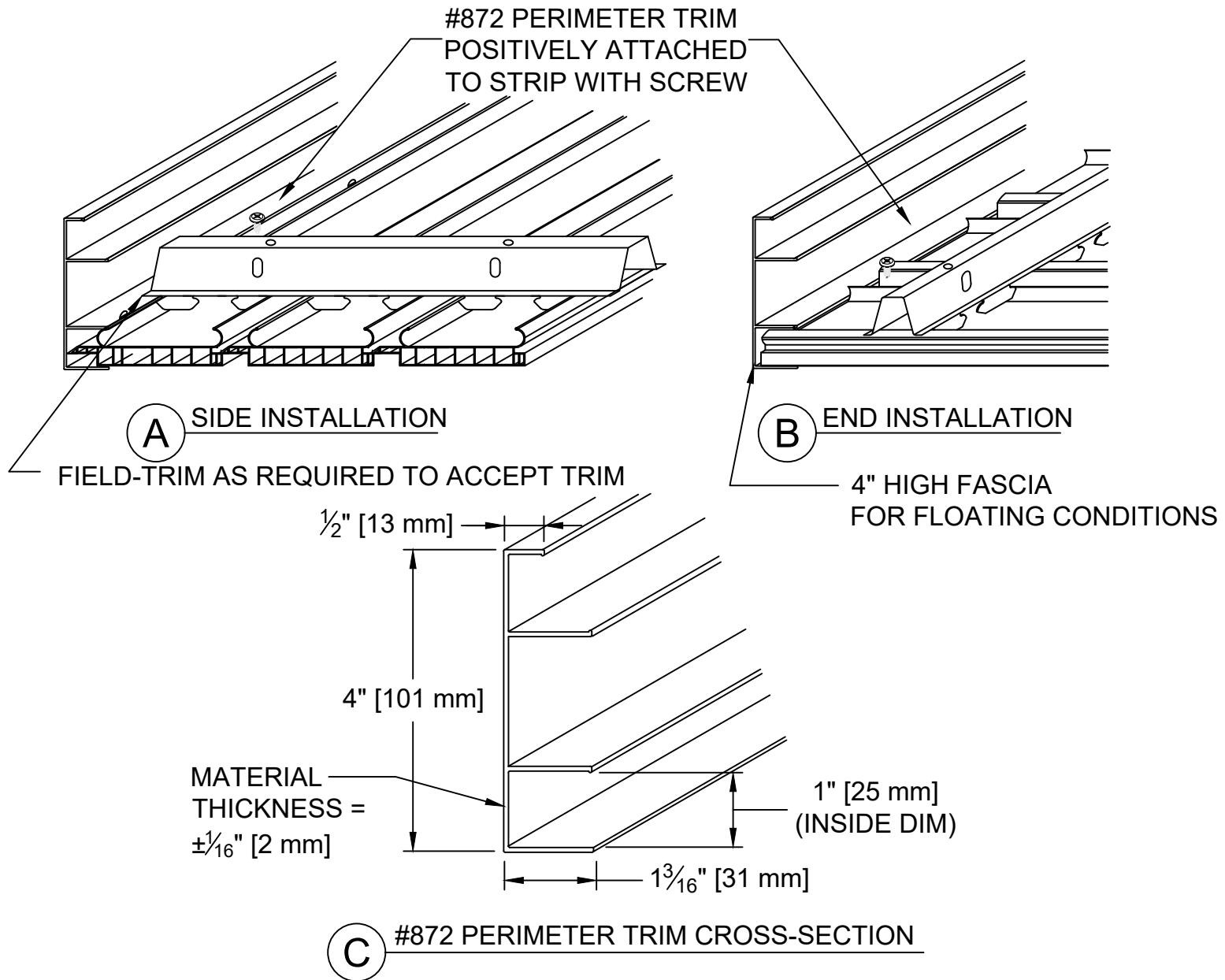

RULON INTERNATIONAL  
2000 Ring Way  
St. Augustine, FL 32092

(904) 584-1400  
info @ rulonco.com

www.rulonco.com

PROJECT:

TITLE: **ENDURE™ 872 Floating 4" High Fascia**

ISSUE DATE:

REVISION DATE:  
**MAR/14/2019**

DRAWN BY:

**CAP**

CHECKED BY:

**TR**

PROJECT NUMBER:

DRAWING NUMBER:

**P9000022**

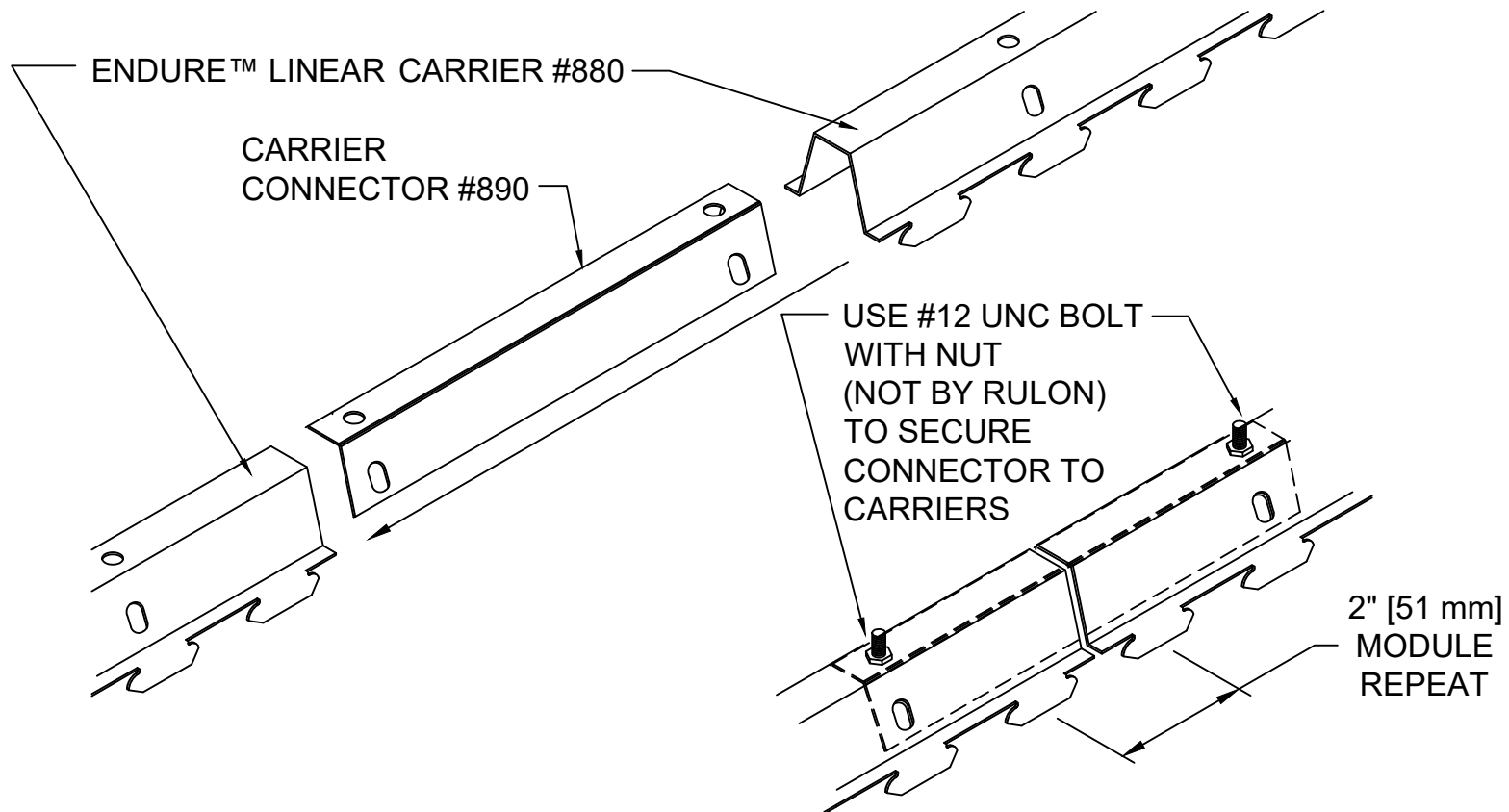

NOTE:  
 CARRIER CONNECTOR IS FOR  
 ALIGNMENT ONLY. SUPPORT  
 CARRIER AS NEEDED NEAR SPLICE.



INSTALLATION TIP:  
 CARRIER CONNECTOR IS DESIGNED TO  
 BE POSITIONED INSIDE (AS SHOWN) OR  
 OUTSIDE OF THE CARRIER; ATTACHED  
 THROUGH HOLES IN TOP (AS SHOWN)  
 OR SIDES



RULON INTERNATIONAL  
 2000 Ring Way  
 St. Augustine, FL 32092

(904) 584-1400  
 info @ rulonco.com

www.rulonco.com

PROJECT:

ISSUE DATE:

DRAWN BY:

PROJECT NUMBER:

CAP

TITLE: **ENDURE™ LINEAR #890 Carrier  
 Connector**

REVISION DATE:

CHECKED BY:

DRAWING NUMBER:

MAR/14/2019

TR

PXX00003

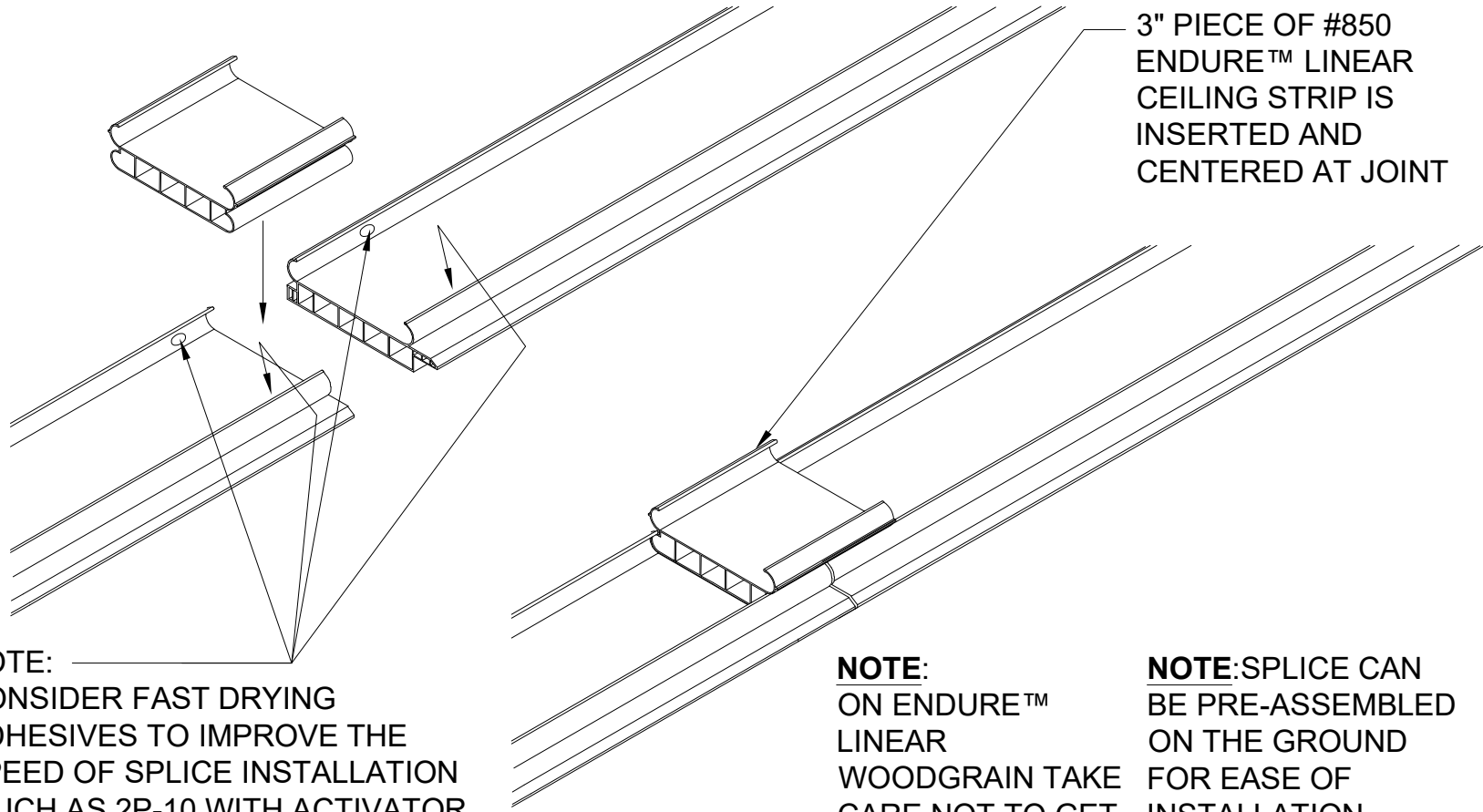

3" PIECE OF #850  
ENDURE™ LINEAR  
CEILING STRIP IS  
INSERTED AND  
CENTERED AT JOINT

**NOTE:**  
CONSIDER FAST DRYING  
ADHESIVES TO IMPROVE THE  
SPEED OF SPLICE INSTALLATION  
(SUCH AS 2P-10 WITH ACTIVATOR  
OR TITEBOND PVC TRIM ADHESIVE)

**NOTE:**  
ON ENDURE™  
LINEAR  
WOODGRAIN TAKE  
CARE NOT TO GET  
ADHESIVE ON  
WOODGRAIN FILM

**NOTE:** SPLICE CAN  
BE PRE-ASSEMBLED  
ON THE GROUND  
FOR EASE OF  
INSTALLATION



RULON INTERNATIONAL  
2000 Ring Way  
St. Augustine, FL 32092  
  
(904) 584-1400  
info @ rulonco.com  
  
www.rulonco.com

PROJECT:	ISSUE DATE:	DRAWN BY:	PROJECT NUMBER:
TITLE: ENDURE™ LINEAR #850S Splice Material	REVISION DATE: APR/24/2026	CAP CHECKED BY: MS/TR	DRAWING NUMBER: P8500004

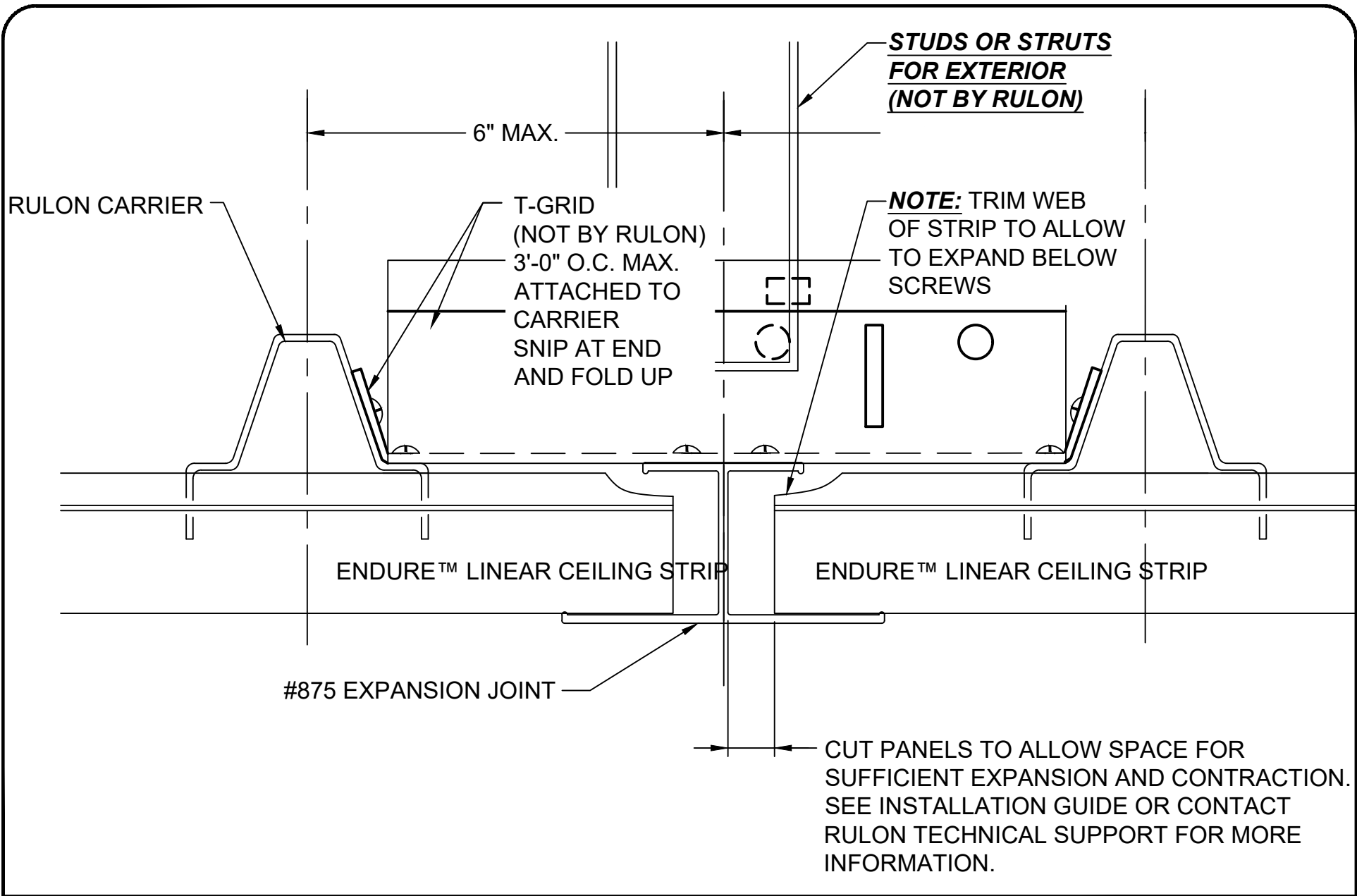

RULON INTERNATIONAL  
 2000 Ring Way  
 St. Augustine, FL 32092

(904) 584-1400  
 info @ rulonco.com

www.rulonco.com

PROJECT:

TITLE: **ENDURE™ LINEAR #875**  
 Expansion Joint Detail

ISSUE DATE:

REVISION DATE:  
**OCT/02/2023**

DRAWN BY:

**CAP**

CHECKED BY:

**TR**

PROJECT NUMBER:

DRAWING NUMBER:

**P9000005**

**CHANNEL STRUT CROSS-SECTION, TYPICAL**

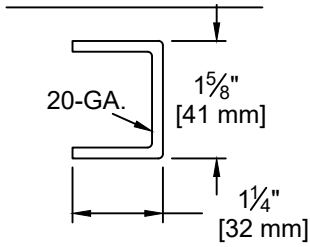

**#12 GA. HANGER WIRE CENTERS AS FOLLOWS:  
 INTERIOR: 4' O.C. MAX (STRUTS OPTIONAL)  
 EXTERIOR: 2' O.C. MAX (STRUTS REQUIRED)**

 **CONTACT RULON ENGINEERING FOR COASTAL APPLICATIONS (PROJECT-SPECIFIC)**

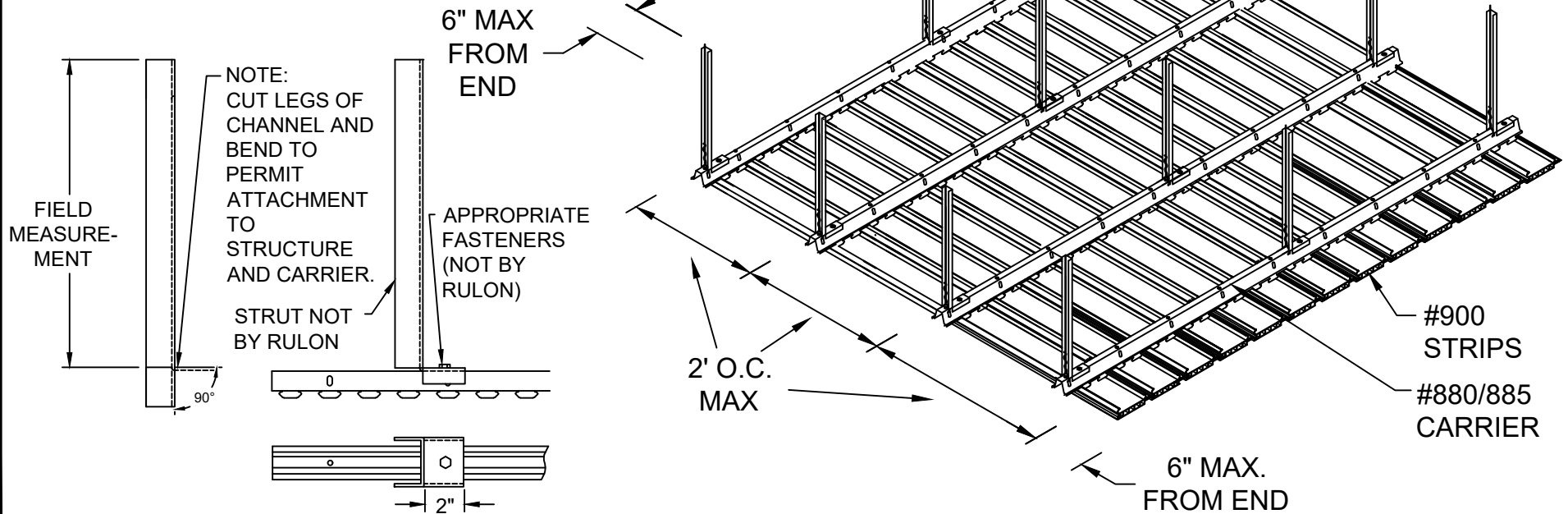

**TYPICAL STRUT**



RULON INTERNATIONAL  
 2000 Ring Way  
 St. Augustine, FL 32092

(904) 584-1400  
 info@rulonco.com

www.rulonco.com

PROJECT:

ISSUE DATE:

DRAWN BY:

PROJECT NUMBER:

CAP

TITLE: **ENDURE™ LINEAR 900  
 Installation - Spacing**

REVISION DATE:

CHECKED BY:

DRAWING NUMBER:

SEP/25/2025

CMP

P9000006

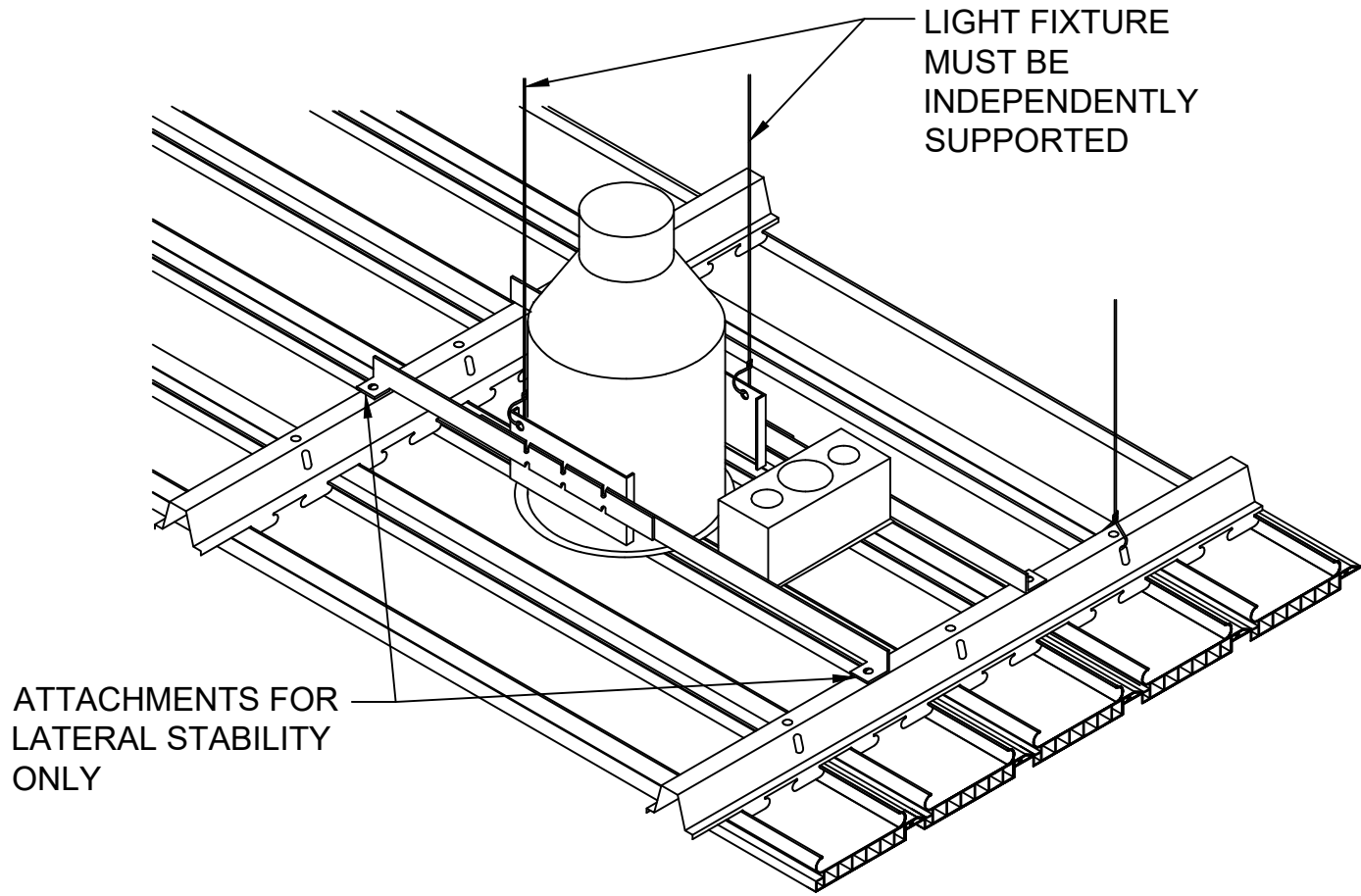

RULON INTERNATIONAL  
2000 Ring Way  
St. Augustine, FL 32092

(904) 584-1400  
info @ rulonco.com

www.rulonco.com

PROJECT:

TITLE: **ENDURE™ LINEAR Recessed  
Can Light Detail**

ISSUE DATE:

REVISION DATE:  
**JUN/23/2015**

DRAWN BY:

**CAP**

CHECKED BY:

**TR**

PROJECT NUMBER:

DRAWING NUMBER:

**P9000008**

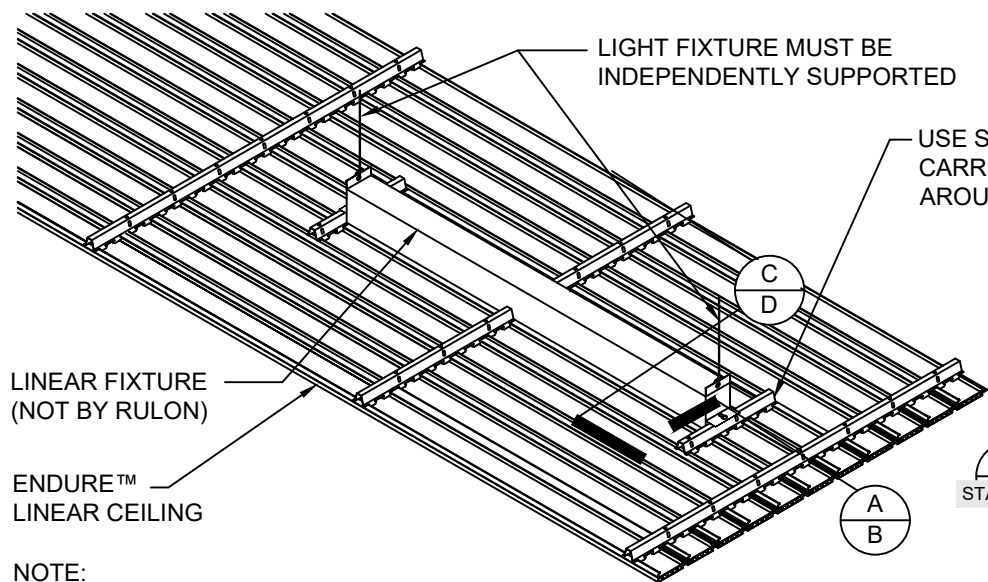

NOTE:  
CEILING CARRIER SUPPORTS  
OMITTED FOR CLARITY

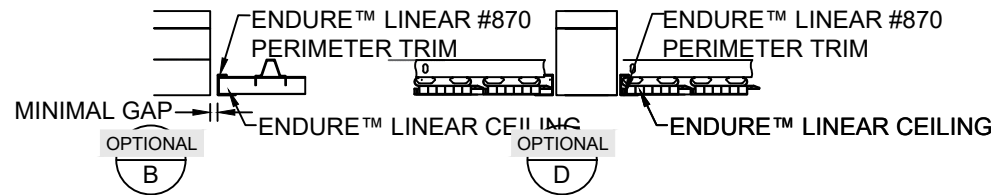
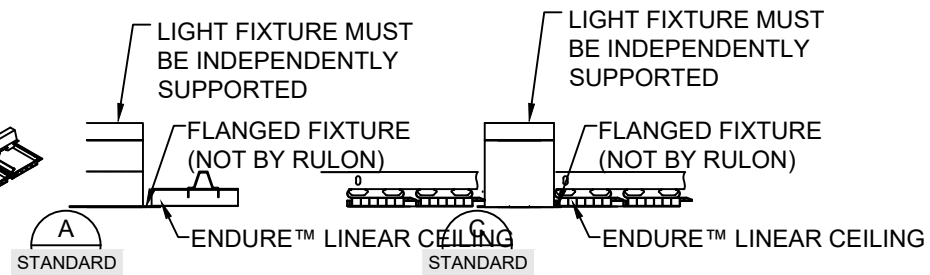

RULON INTERNATIONAL  
2000 Ring Way  
St. Augustine, FL 32092

(904) 584-1400  
info @ rulonco.com

www.rulonco.com

PROJECT:

TITLE: **ENDURE™ with Linear Light  
Fixture**

ISSUE DATE:

REVISION DATE:  
**JAN/31/2023**

DRAWN BY:

**CAP**

CHECKED BY:

**CRD**

PROJECT NUMBER:

DRAWING NUMBER:

**P9000009**

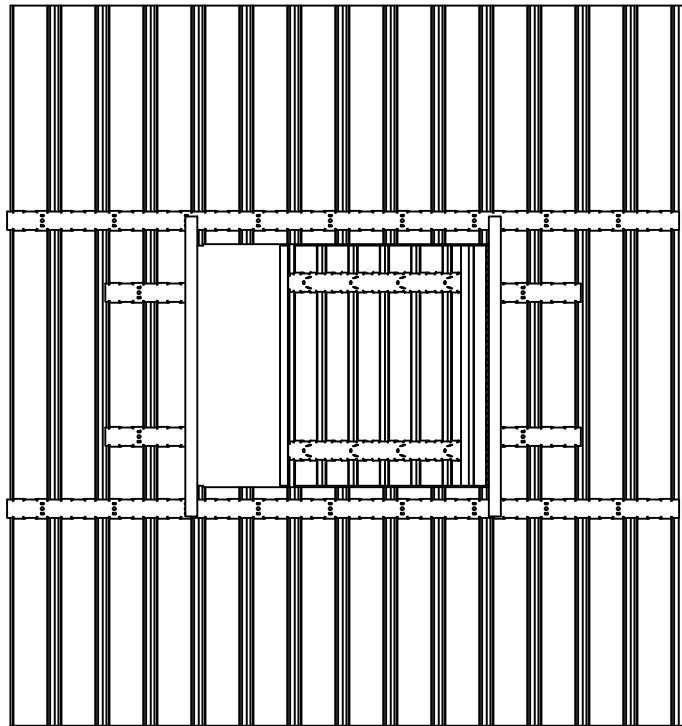

**PLAN VIEW**  
(ACCESS PANEL PARTIALLY OPEN)

SEE HINGE DETAIL BELOW  
SEE LATCH DETAIL BELOW

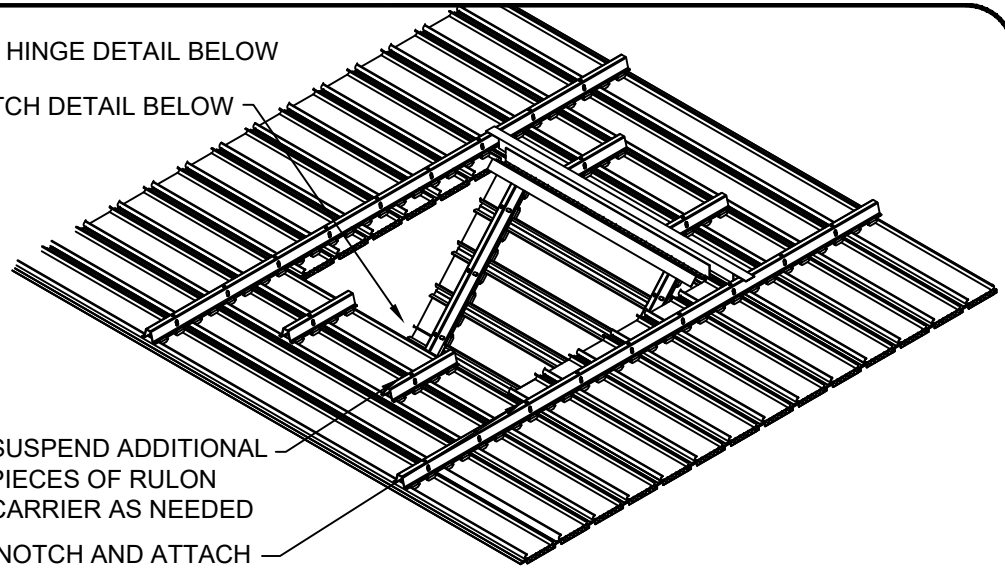

SUSPEND ADDITIONAL  
PIECES OF RULON  
CARRIER AS NEEDED  
FIELD-NOTCH AND ATTACH  
1" [25 mm] L-ANGLE  
(NOT BY RULON)

**NOM. 2' X 2' ACCESS PANEL SHOWN**  
(SIZE VARIES PER PROJECT)

1" [25 mm] L-ANGLE ATTACHED TO ENDURE™ LINEAR CARRIER  
WITH MACHINE SCREWS AND NUTS (NOT BY RULON)

ATTACH HINGE TO L-ANGLE (NOT BY RULON)

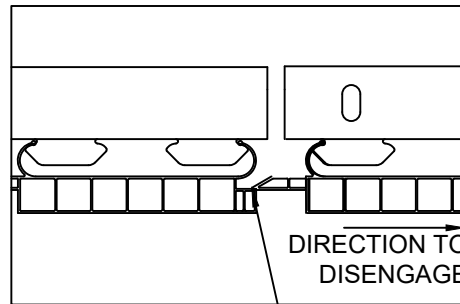

**LATCH DETAIL**  
(SHOWN CLOSED)

DIRECTION TO  
DISENGAGE

INTERFERENCE  
FIT - APPLY  
PRESSURE TO  
DISENGAGE

1½" [38 mm] DOOR  
HINGE, ATTACHED  
TO L-ANGLE WITH  
MACHINE SCREWS  
AND NUTS  
(NOT BY RULON)

REMOVE INTEGRAL  
SPACER IN FIELD  
WITH ROUTER  
(ENDURE™ LINEAR  
900 ONLY)

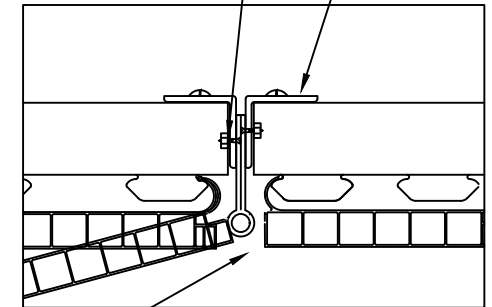

**HINGE DETAIL**  
(SHOWN CLOSED)



RULON INTERNATIONAL  
2000 Ring Way  
St. Augustine, FL 32092

(904) 584-1400  
info @ rulonco.com

www.rulonco.com

PROJECT:

ISSUE DATE:

DRAWN BY:

PROJECT NUMBER:

CAP

TITLE: **ENDURE™ 900 Access Panel  
Detail**

REVISION DATE:  
**OCT/25/2024**

CHECKED BY:  
**TR**

DRAWING NUMBER:  
**P9000010**

SHIM UNDER STUDS/STRUCTURE WHERE NECESSARY TO LEVEL THE CARRIERS

METAL STUDS OR STRUCTURE (NOT BY RULON)

METAL STUD

SHIM

#880 CARRIER

#880 CARRIER

ATTACH #880 CARRIER TO METAL STUDS /STRUCTURE USING SCREWS 2' ON CENTER\*\* (NOT BY RULON)

\*\*WHEN ATTACHING TO PLYWOOD SHEATHING/FURRING USE SCREWS 1' O.C. TYPICAL



RULON INTERNATIONAL  
2000 Ring Way  
St. Augustine, FL 32092

(904) 584-1400  
info @ rulonco.com

www.rulonco.com

PROJECT:

TITLE: **ENDURE™ LINEAR Direct Mount Detail**

ISSUE DATE:

REVISION DATE:  
**DEC/17/2025**

DRAWN BY:

**CAP**

CHECKED BY:

**CMP**

PROJECT NUMBER:

DRAWING NUMBER:

**PXX00012**

<u>DRAWING #</u>	<u>TITLE</u>
P-960-1	ENDURE™ Linear #960 (6 Inch Module with Integrated Spacer) Profile
P-960-2	ENDURE™ Linear #960 with #870 Perimeter Trim
P-960-22	ENDURE™ Linear #960 with #872 4" High Fascia Trim
P-960-3	ENDURE™ Linear Carrier Connector
P-960-4	ENDURE™ Linear #851S 5 Inch Splice Material
P-960-5	ENDURE™ Linear #875 Expansion Joint Detail
P-960-6	ENDURE™ Linear #960 Installation / Spacing
P-960-8	ENDURE™ Linear #960 Recessed Can Light
P-960-9	ENDURE™ Linear #960 Linear Fixture Detail
P-960-10	ENDURE™ Linear #960 Access Panel Detail

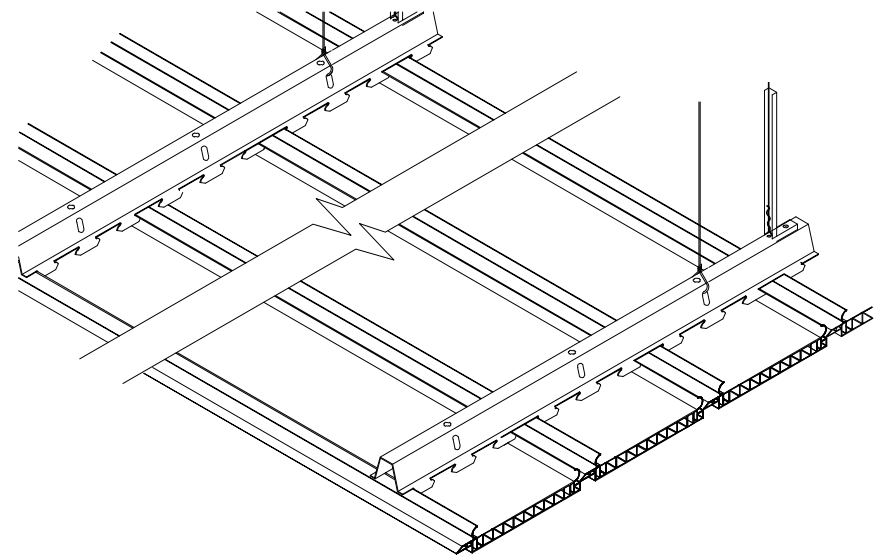

RULON INTERNATIONAL  
2000 Ring Way  
St. Augustine, FL 32092

(904) 584-1400  
info @ rulonco.com

www.rulonco.com

PROJECT:

TITLE: **Endure™ Linear 960 Index  
6 Inch Module**

ISSUE DATE:

REVISION DATE:  
**DEC/16/2025**

DRAWN BY:

**CAP**

CHECKED BY:

**CMP**

PROJECT NUMBER:

DRAWING NUMBER:

**P-960-IN**

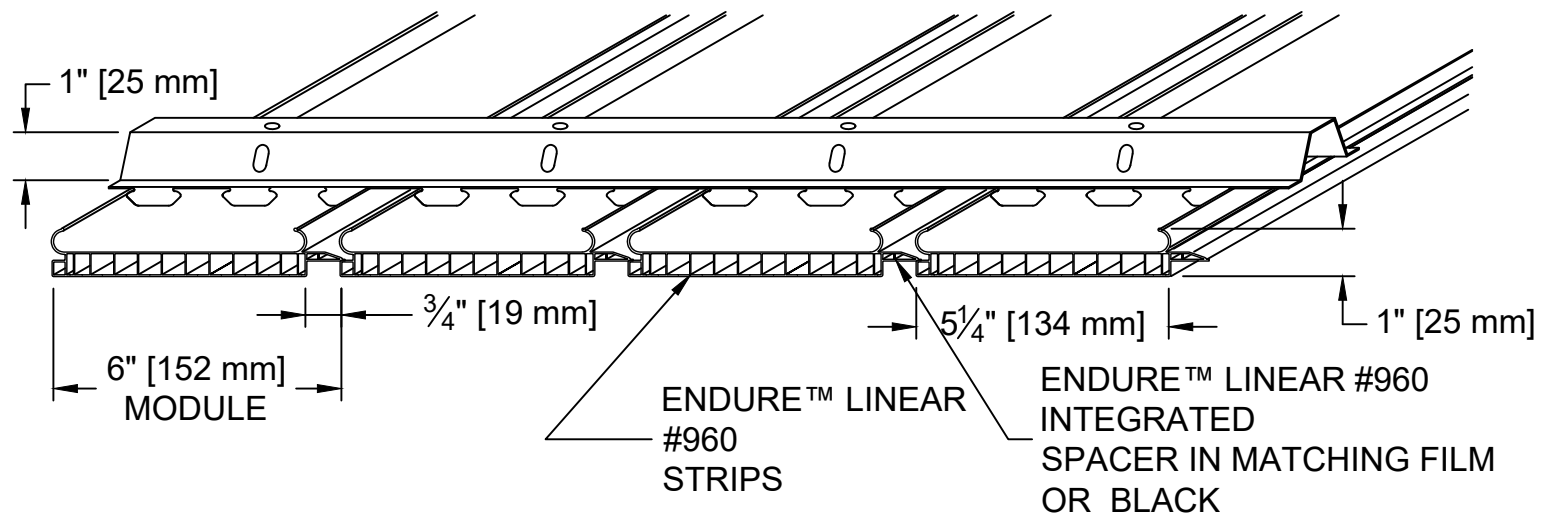

RULON INTERNATIONAL  
2000 Ring Way  
St. Augustine, FL 32092

(904) 584-1400  
info @ rulonco.com

www.rulonco.com

PROJECT:

ISSUE DATE:

DRAWN BY:

PROJECT NUMBER:

CAP

TITLE:

ENDURE™ Linear #960 (6 Inch  
Module with Integrated Spacer) Profile

REVISION DATE:

DEC/01/2025

CHECKED BY:

CMP

DRAWING NUMBER:

P-960-1

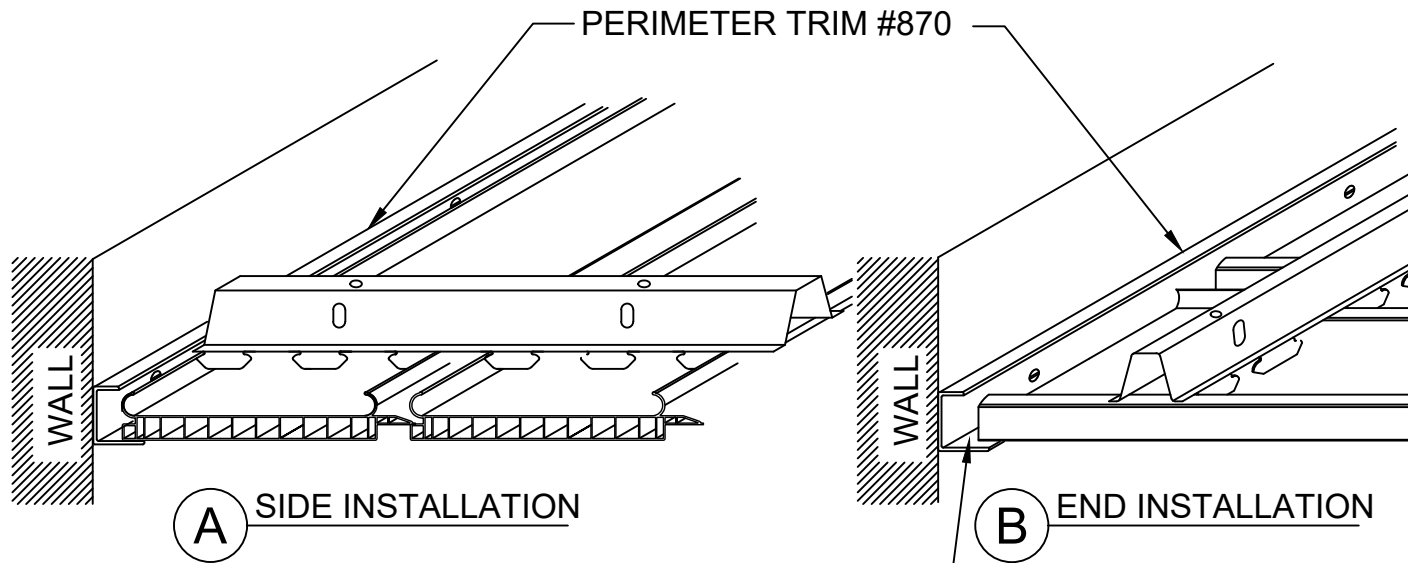

NOTE:  
ALLOW SUFFICIENT SPACE FOR  
EXPANSION AT PERIMETER.  
SEE INSTALLATION GUIDE FOR  
MORE INFORMATION

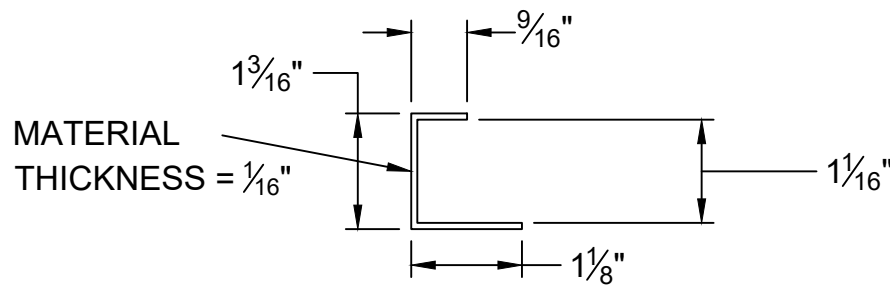

(C) #870 PERIMETER TRIM CROSS-SECTION



RULON INTERNATIONAL  
2000 Ring Way  
St. Augustine, FL 32092

(904) 584-1400  
info @ rulonco.com

www.rulonco.com

PROJECT:

TITLE: ENDURE™ Linear #960 with #870  
Perimeter Trim

ISSUE DATE:

REVISION DATE:  
DEC/01/2025

DRAWN BY:

CAP

CHECKED BY:

CMP

PROJECT NUMBER:

DRAWING NUMBER:

P-960-2

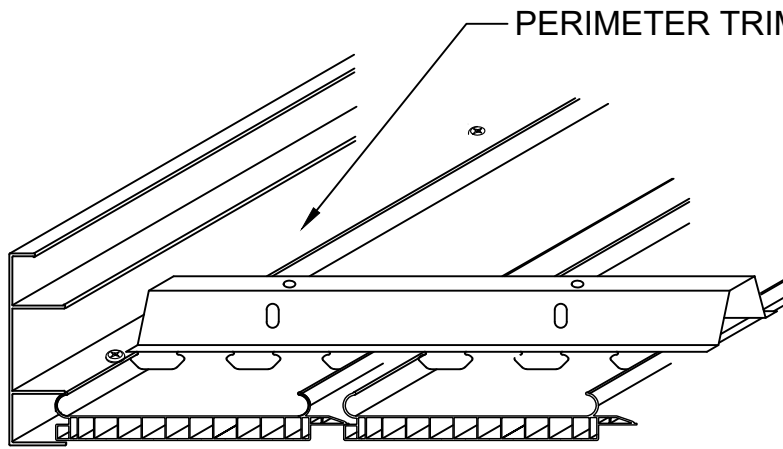

**A** SIDE INSTALLATION

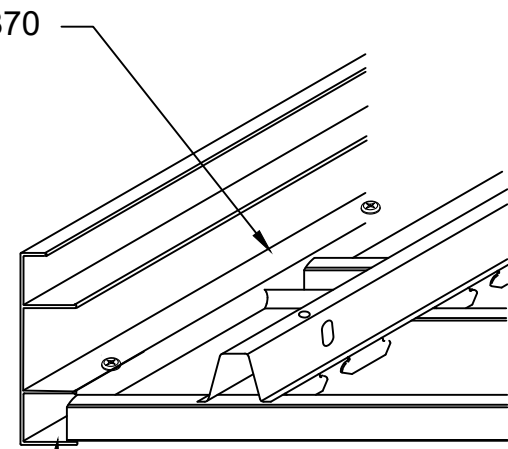

**B** END INSTALLATION

**NOTE:**  
 ALLOW SUFFICIENT SPACE FOR  
 EXPANSION AT PERIMETER.  
 SEE INSTALLATION GUIDE FOR  
 MORE INFORMATION

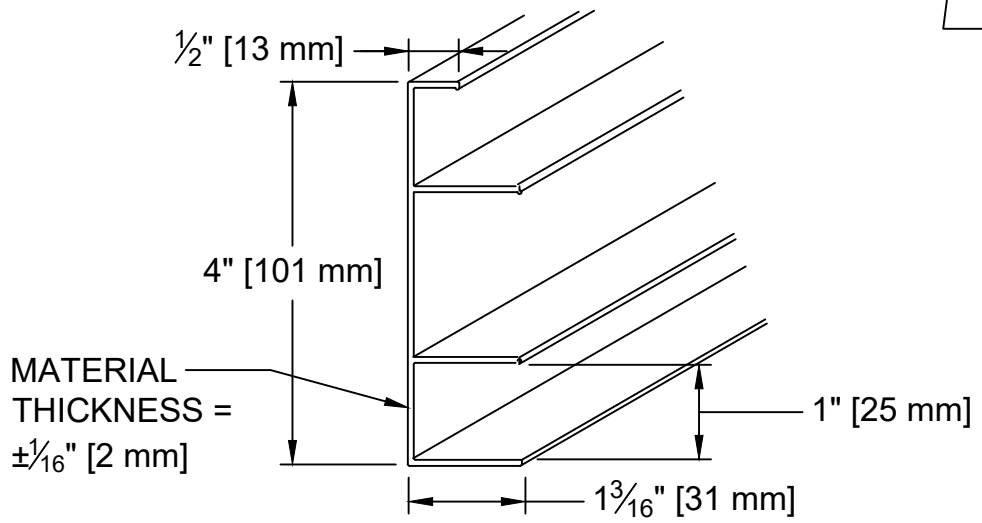

**C** #872 PERIMETER TRIM CROSS-SECTION

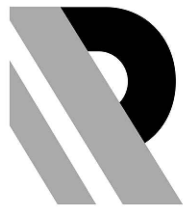

RULON INTERNATIONAL  
 2000 Ring Way  
 St. Augustine, FL 32092  
 (904) 584-1400  
 info @ rulonco.com  
 www.rulonco.com

PROJECT:	ISSUE DATE:	DRAWN BY: <b>CAP</b>	PROJECT NUMBER:
TITLE: <b>ENDURE™ Linear #960 with #872 4" High Fascia Trim</b>	REVISION DATE: <b>DEC/01/2025</b>	CHECKED BY: <b>CMP</b>	DRAWING NUMBER: <b>P-960-22</b>

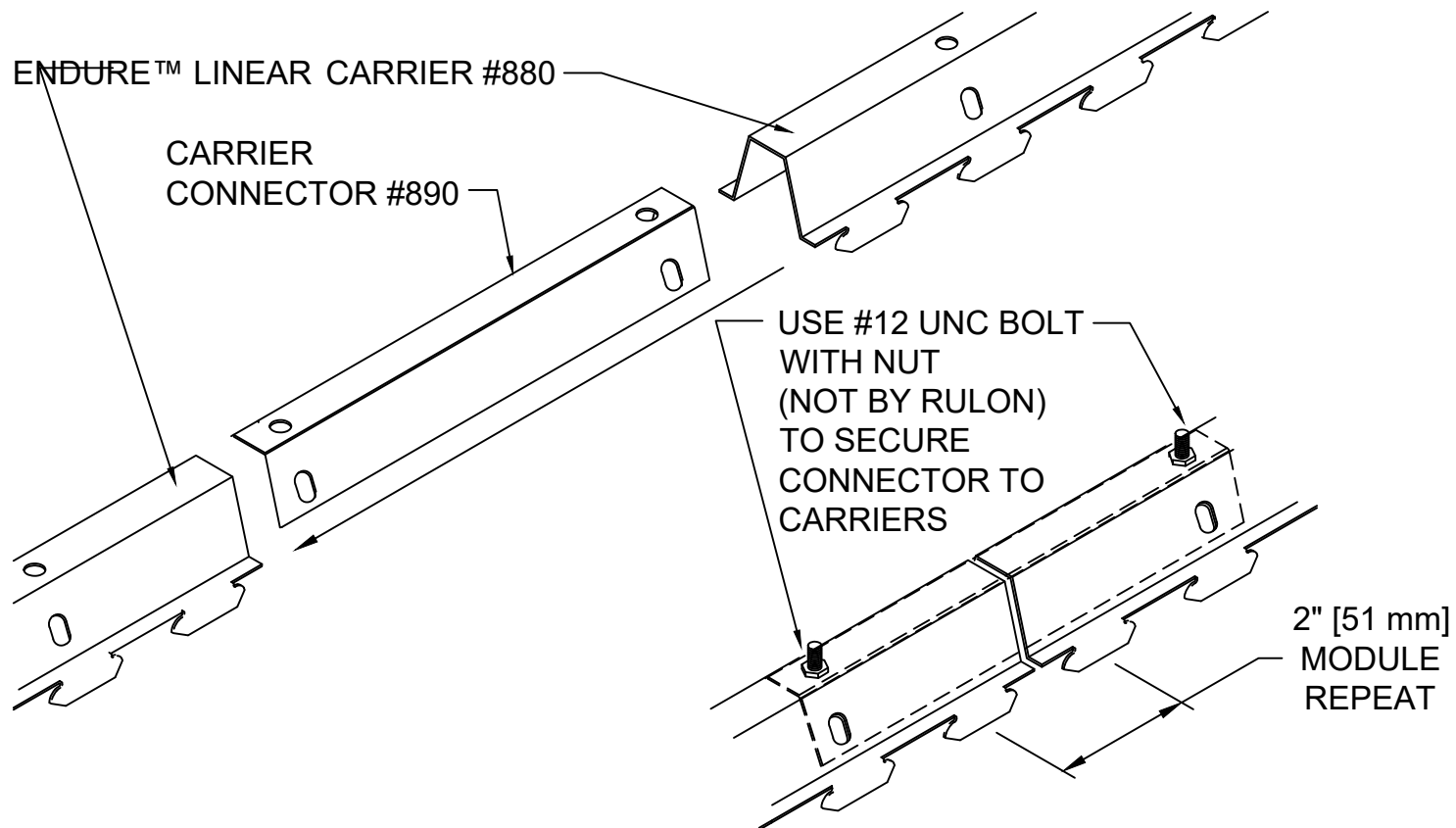

NOTE:  
CARRIER CONNECTOR IS FOR ALIGNMENT ONLY. SUPPORT CARRIER AS NEEDED NEAR SPLICE.

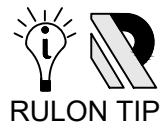

INSTALLATION TIP:  
CARRIER CONNECTOR IS DESIGNED TO BE POSITIONED INSIDE (AS SHOWN) OR OUTSIDE OF THE CARRIER; ATTACHED THROUGH HOLES IN TOP (AS SHOWN) OR SIDES



RULON INTERNATIONAL  
2000 Ring Way  
St. Augustine, FL 32092

(904) 584-1400  
info @ rulonco.com

www.rulonco.com

PROJECT:

ISSUE DATE:

DRAWN BY:

PROJECT NUMBER:

CAP

TITLE: ENDURE™ Linear Carrier  
Connector

REVISION DATE:  
DEC/01/2025

CHECKED BY:

DRAWING NUMBER:

CMP

P-960-3

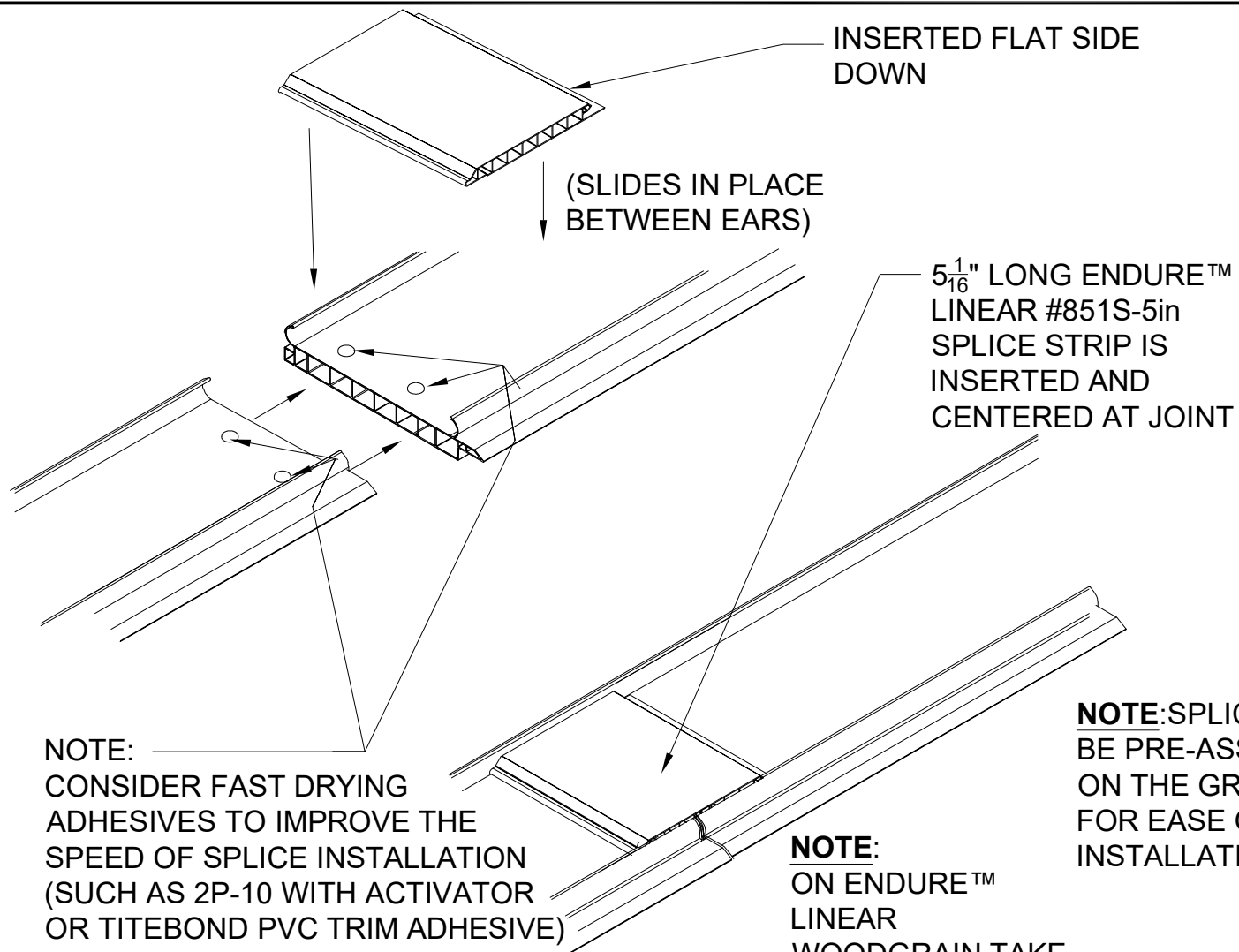

**NOTE:** CONSIDER FAST DRYING ADHESIVES TO IMPROVE THE SPEED OF SPLICE INSTALLATION (SUCH AS 2P-10 WITH ACTIVATOR OR TITEBOND PVC TRIM ADHESIVE)

**NOTE:** ON ENDURE™ LINEAR WOODGRAIN TAKE CARE NOT TO GET ADHESIVE ON WOODGRAIN FILM

**NOTE:** SPLICE CAN BE PRE-ASSEMBLED ON THE GROUND FOR EASE OF INSTALLATION



RULON INTERNATIONAL  
2000 Ring Way  
St. Augustine, FL 32092

(904) 584-1400  
info @ rulonco.com

www.rulonco.com

PROJECT:

TITLE: ENDURE™ Linear #851S 5 Inch  
Splice Material

ISSUE DATE:

REVISION DATE:  
APR/27/2026

DRAWN BY:

CAP

CHECKED BY:

MS/TR

PROJECT NUMBER:

DRAWING NUMBER:

P-960-4

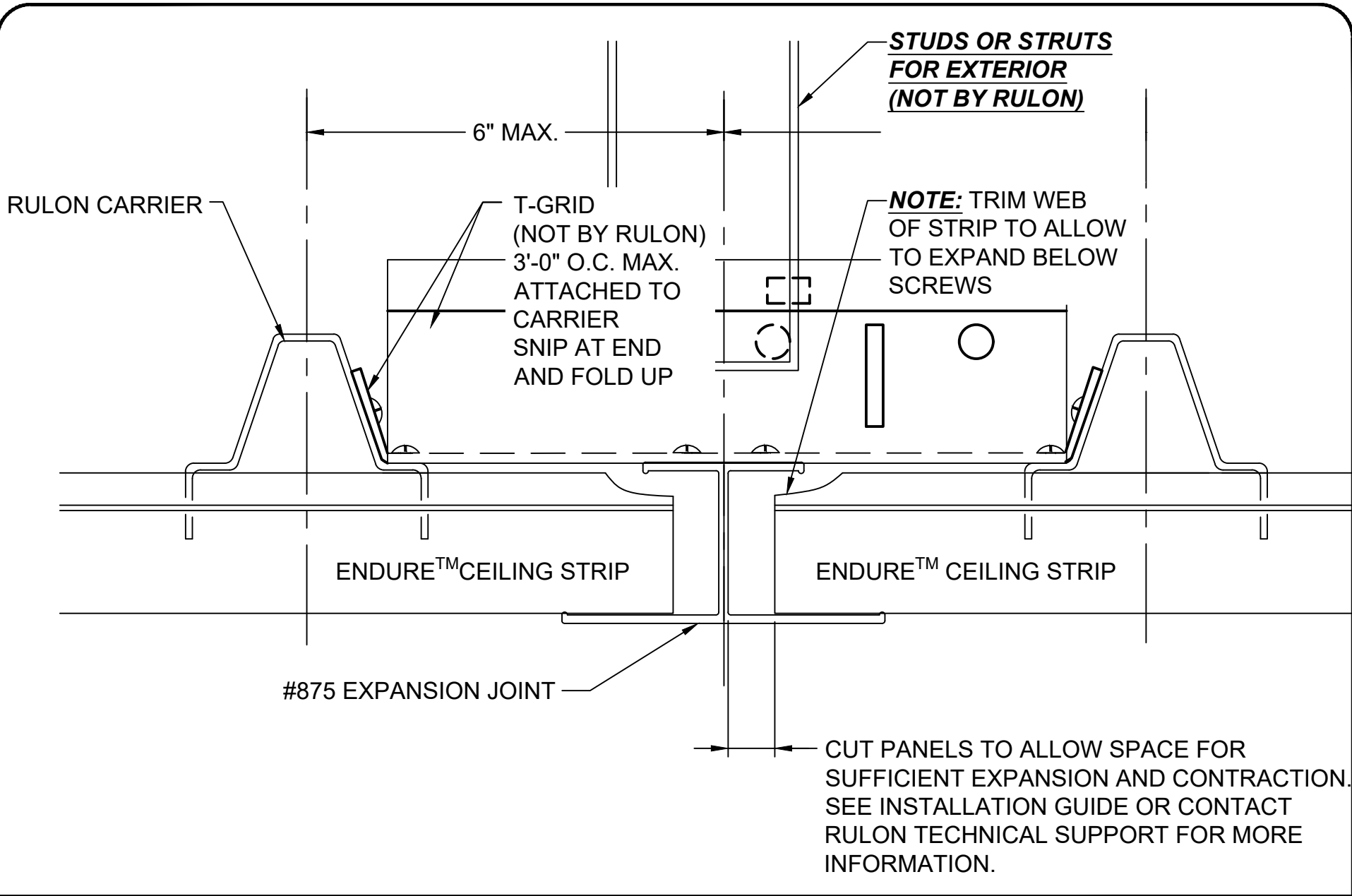

RULON INTERNATIONAL  
2000 Ring Way  
St. Augustine, FL 32092

(904) 584-1400  
info @ rulonco.com

www.rulonco.com

PROJECT:

TITLE: **ENDURE™ Linear #875**  
Expansion Joint Detail

ISSUE DATE:

REVISION DATE:  
DEC/01/2025

DRAWN BY:

CAP

CHECKED BY:

CMP

PROJECT NUMBER:

DRAWING NUMBER:

P-960-5

CHANNEL STRUT  
CROSS-SECTION,  
TYPICAL

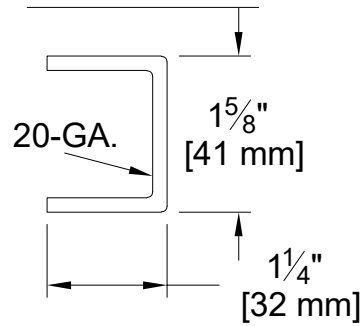

**#12 GA. HANGER WIRE  
CENTERS AS FOLLOWS:  
INTERIOR: 4' O.C. MAX  
(STRUTS OPTIONAL)  
EXTERIOR: 2' O.C. MAX  
(STRUTS REQUIRED)  
(6" MAX FROM ENDS)**

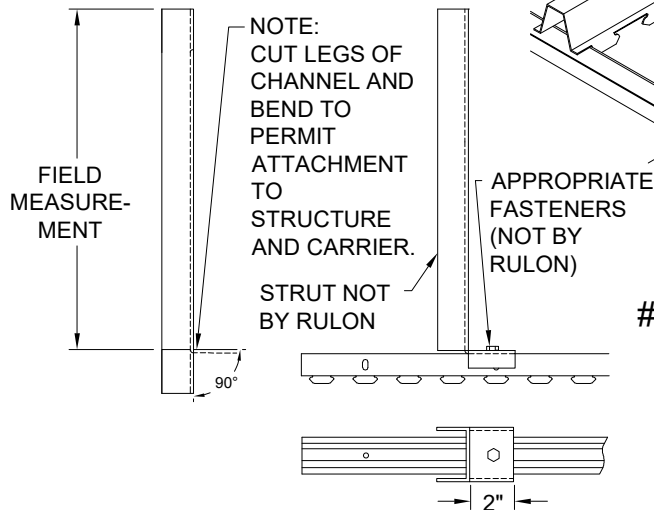
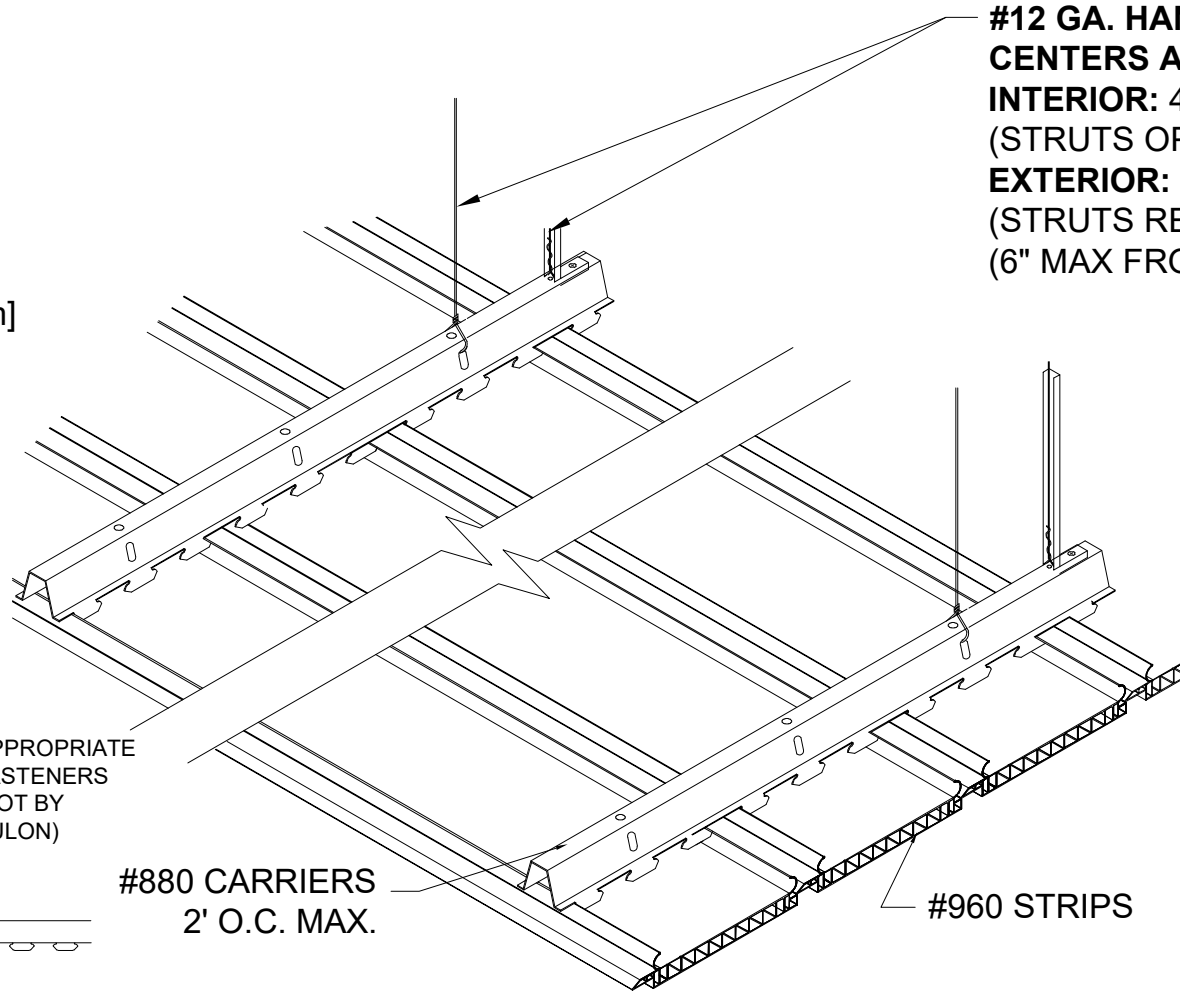

RULON INTERNATIONAL  
2000 Ring Way  
St. Augustine, FL 32092

(904) 584-1400  
info @ rulonco.com

www.rulonco.com

PROJECT:

TITLE: **ENDURE™ Linear 960 Installation  
/ Spacing**

ISSUE DATE:

REVISION DATE:  
**DEC/15/2025**

DRAWN BY:

**CAP**

CHECKED BY:

**CMP**

PROJECT NUMBER:

DRAWING NUMBER:

**P960-INSTALL**

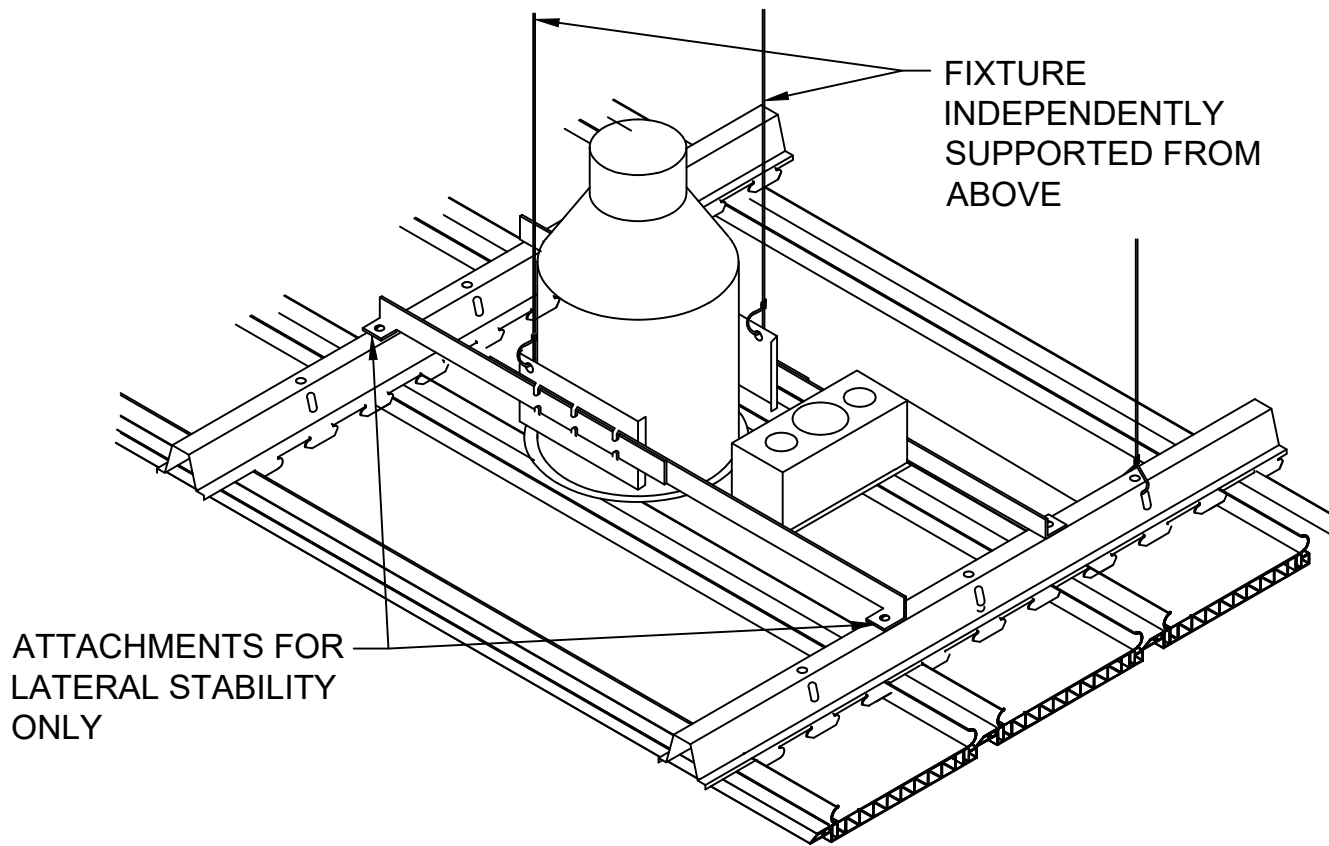

RULON INTERNATIONAL  
2000 Ring Way  
St. Augustine, FL 32092

(904) 584-1400  
info @ rulonco.com

www.rulonco.com

PROJECT:

TITLE: **ENDURE™ Linear #960**  
Recessed Can Light Detail

ISSUE DATE:

REVISION DATE:  
**DEC/01/2025**

DRAWN BY:

**CAP**

CHECKED BY:

**CMP**

PROJECT NUMBER:

DRAWING NUMBER:

**P-960-8**

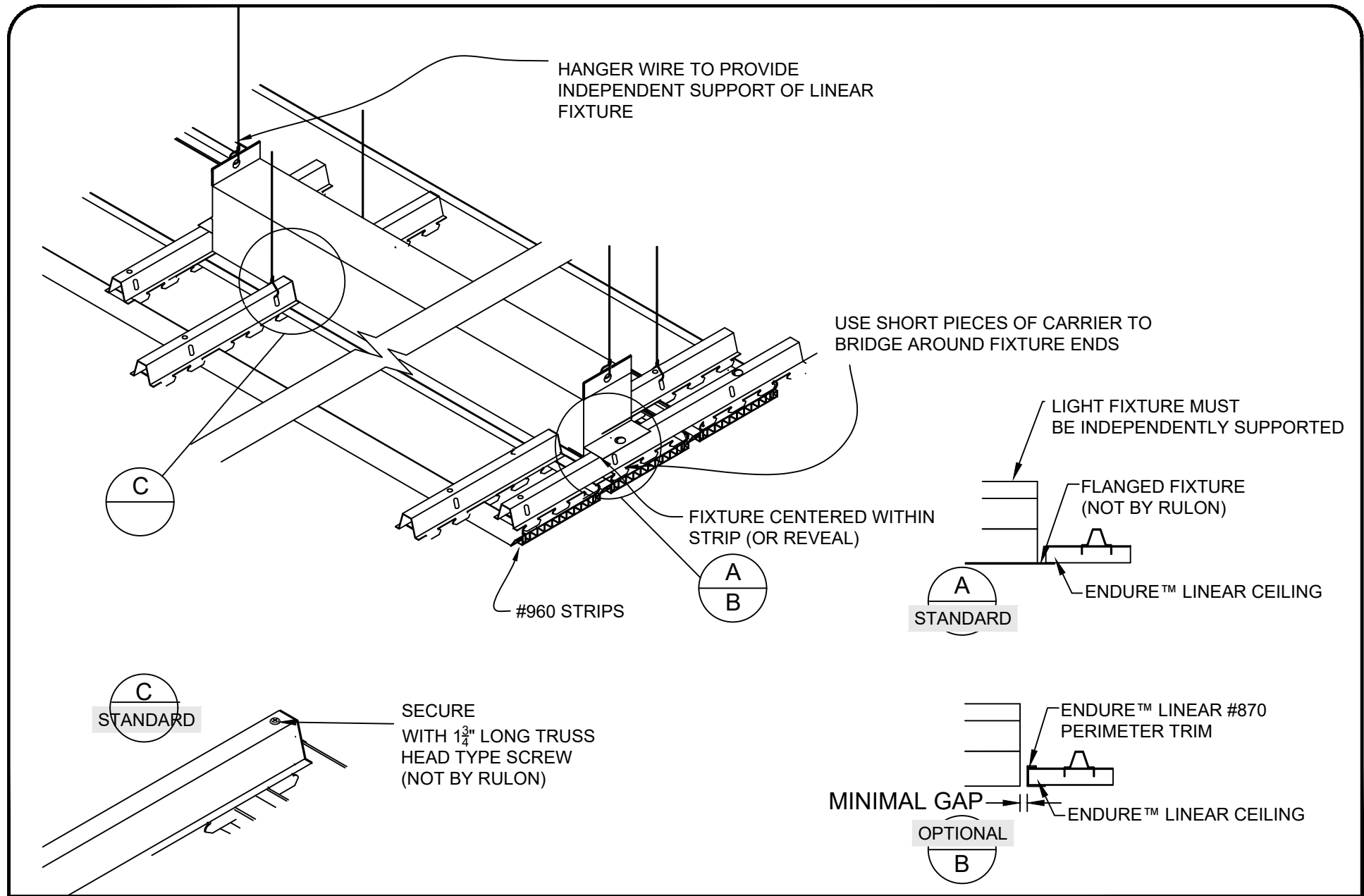

RULON INTERNATIONAL  
 2000 Ring Way  
 St. Augustine, FL 32092

(904) 584-1400  
 info @ rulonco.com

www.rulonco.com

PROJECT:

TITLE: **ENDURE™ Linear #960 Linear  
 Fixture Detail**

ISSUE DATE:

REVISION DATE:  
**DEC/01/2025**

DRAWN BY:

**CAP**

CHECKED BY:

**CMP**

PROJECT NUMBER:

DRAWING NUMBER:

**P-960-9**

SEE HINGE DETAIL BELOW  
SEE LATCH DETAIL BELOW

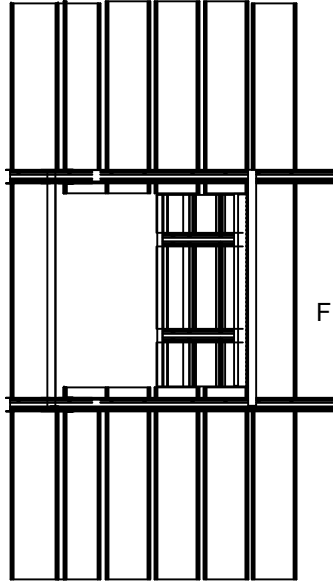

**PLAN VIEW**  
(ACCESS PANEL PARTIALLY OPEN)

SUSPEND ADDITIONAL  
PIECES OF RULON  
CARRIER AS NEEDED  
FIELD-NOTCH AND ATTACH  
1" [25 mm] L-ANGLE  
(NOT BY RULON)

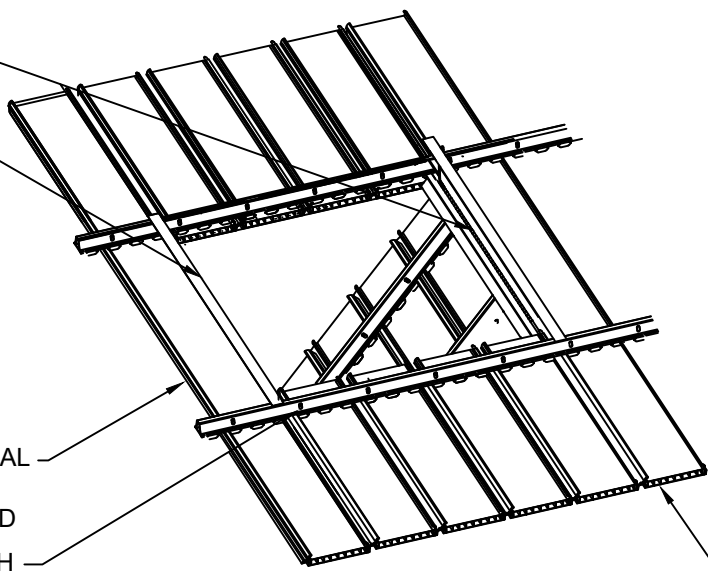

**NOM. 2' X 2' ACCESS PANEL SHOWN**  
(SIZE VARIES PER PROJECT)

ENDURE™ LINEAR #960  
CEILING

1" [25 mm] L-ANGLE ATTACHED TO ENDURE™ LINEAR CARRIER  
WITH MACHINE SCREWS AND NUTS (NOT BY RULON)  
ATTACH HINGE TO L-ANGLE (NOT BY RULON)

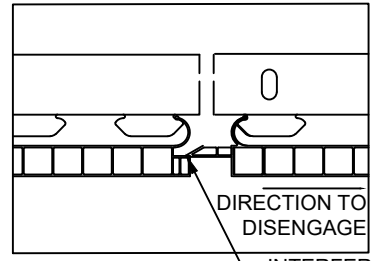

LATCH DETAIL  
(SHOWN CLOSED)

DIRECTION TO  
DISENGAGE  
INTERFERENCE  
FIT - APPLY  
PRESSURE TO  
DISENGAGE

1/2" [38 mm] DOOR  
HINGE, ATTACHED  
TO L-ANGLE WITH  
MACHINE SCREWS  
AND NUTS  
(NOT BY RULON)

REMOVE INTEGRAL  
SPACER IN FIELD  
WITH ROUTER  
FIT - APPLY  
(ENDURE™ LINEAR  
910 ONLY)

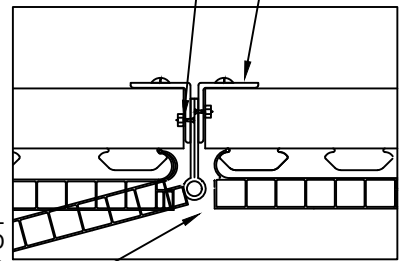

HINGE DETAIL  
(SHOWN CLOSED)



RULON INTERNATIONAL  
2000 Ring Way  
St. Augustine, FL 32092  
  
(904) 584-1400  
info @ rulonco.com  
  
www.rulonco.com

PROJECT:

ISSUE DATE:

DRAWN BY:  
**CAP**

PROJECT NUMBER:

TITLE: **ENDURE™ Linear #960 Access  
Panel Detail**

REVISION DATE:  
**DEC/01/2025**

CHECKED BY:  
**CMP**

DRAWING NUMBER:  
**P-960-10**

<u>DRAWING #</u>	<u>TITLE</u>
P-910XXXP	ENDURE™ Linear #910 (8 Inch Module with Integrated Spacer) Profile
P910-870PT	ENDURE™ Linear #910 with #870 Perimeter Trim
P910-872	ENDURE™ Linear #910 with #872 4" High Fascia Trim
P910-851	ENDURE™ Linear #851S 8 Inch Splice Material
P910-INSTALL	ENDURE™ Linear #910 Installation / Spacing
P910-CLIGHT	ENDURE™ Linear #910 Recessed Can Light
P910-LINF	ENDURE™ Linear #910 Linear Fixture Detail
P910AP-H	ENDURE™ Linear #910 Access Panel Detail

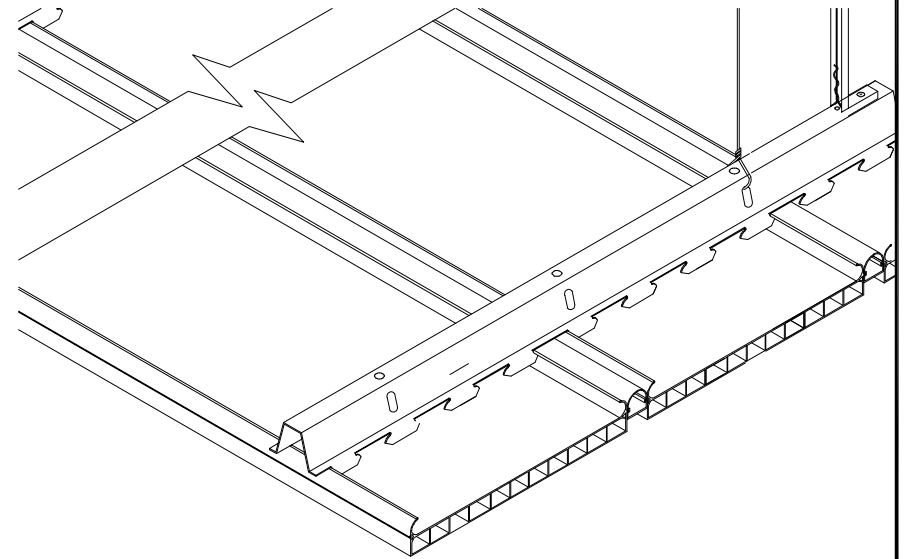

RULON INTERNATIONAL  
2000 Ring Way  
St. Augustine, FL 32092

(904) 584-1400  
info @ rulonco.com

www.rulonco.com

PROJECT:

TITLE: **Endure™ Linear 910 Index  
8 Inch Module**

ISSUE DATE:

REVISION DATE:  
**DEC/01/2025**

DRAWN BY:

**CAP**

CHECKED BY:

**CMP**

PROJECT NUMBER:

DRAWING NUMBER:

**P-910-IN**

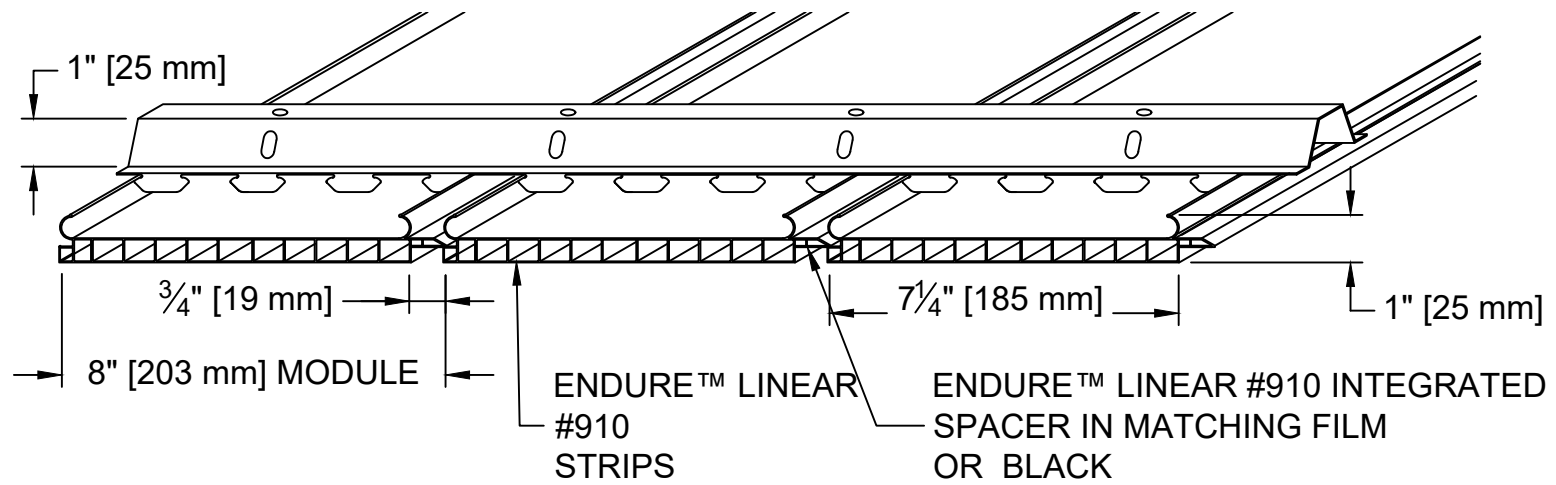

RULON INTERNATIONAL  
2000 Ring Way  
St. Augustine, FL 32092

(904) 584-1400  
info @ rulonco.com

www.rulonco.com

PROJECT:

TITLE: ENDURE™ LINEAR #910 8"  
Module with  
Integrated Spacer Profile

ISSUE DATE:

REVISION DATE:  
DEC/06/2023

DRAWN BY:

CAP

CHECKED BY:

TR

PROJECT NUMBER:

DRAWING NUMBER:

P910XXXP

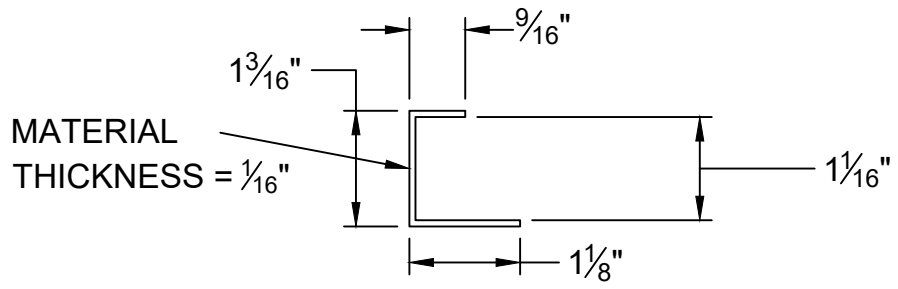

**C** #870 PERIMETER TRIM CROSS-SECTION

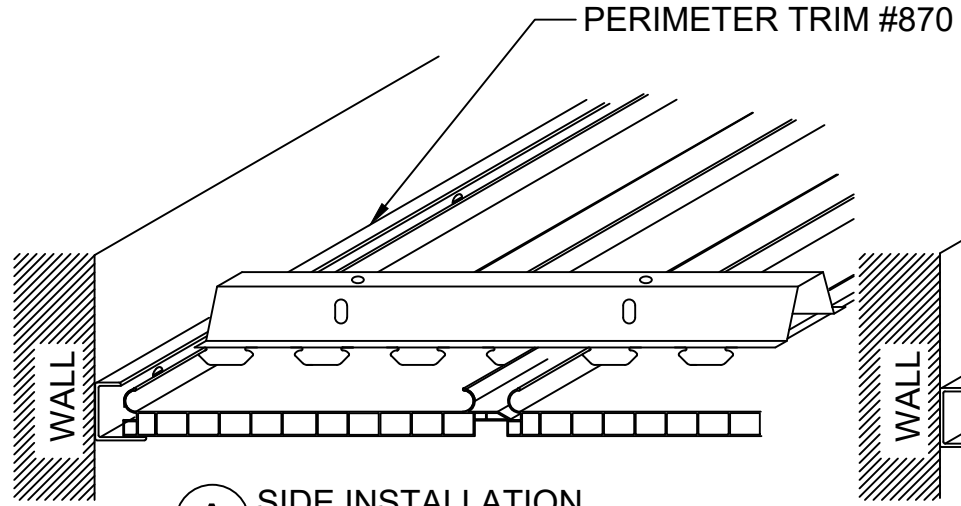

**A** SIDE INSTALLATION

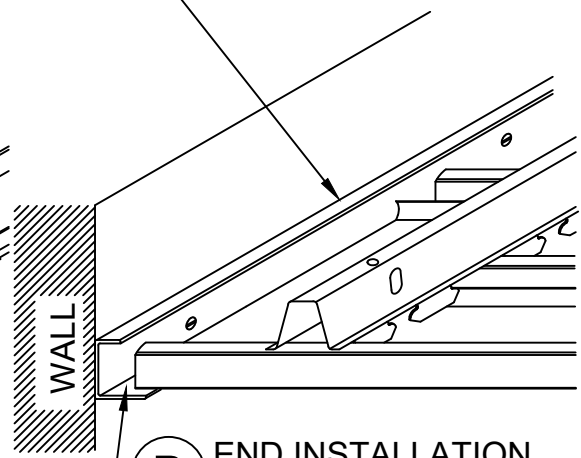

**B** END INSTALLATION

NOTE:  
ALLOW SUFFICIENT SPACE FOR  
EXPANSION AT PERIMETER.  
SEE INSTALLATION GUIDE FOR  
MORE INFORMATION



RULON INTERNATIONAL  
2000 Ring Way  
St. Augustine, FL 32092  
  
(904) 584-1400  
info @ rulonco.com  
  
www.rulonco.com

PROJECT:	ISSUE DATE:	DRAWN BY: <b>CAP</b>	PROJECT NUMBER:
TITLE: <b>ENDURE™ LINEAR#910 8"</b> Integrated Spacer #870 Perimeter Trim	REVISION DATE: <b>DEC/07/2023</b>	CHECKED BY: <b>TR</b>	DRAWING NUMBER: <b>P910-870PT</b>

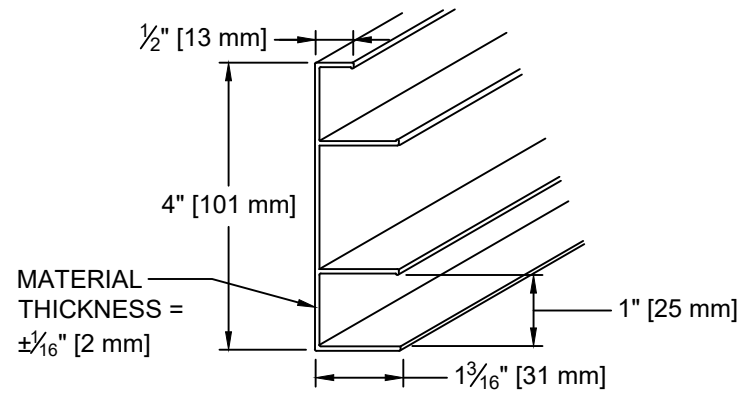

**C** #872 PERIMETER TRIM CROSS-SECTION

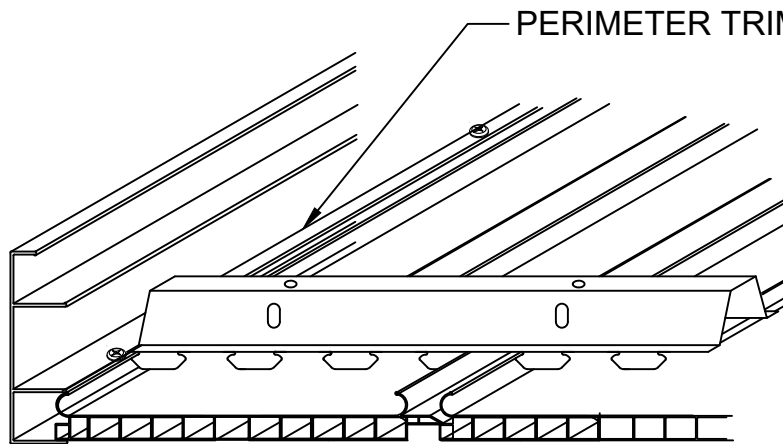

**A** SIDE INSTALLATION

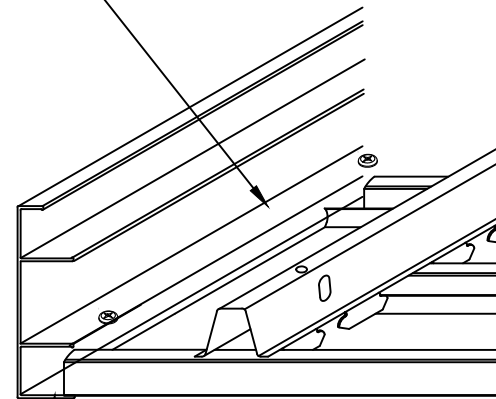

**B** END INSTALLATION

NOTE:  
 ALLOW SUFFICIENT SPACE FOR EXPANSION AT PERIMETER.  
 SEE INSTALLATION GUIDE FOR MORE INFORMATION



RULON INTERNATIONAL  
 2000 Ring Way  
 St. Augustine, FL 32092

(904) 584-1400  
 info @ rulonco.com

www.rulonco.com

PROJECT:

TITLE: **ENDURE™ LINEAR#910 8"**  
**Integrated Spacer**  
**#872 4" Perimeter Trim**

ISSUE DATE:

REVISION DATE:  
**DEC/07/2023**

DRAWN BY:

**CAP**

CHECKED BY:

**TR**

PROJECT NUMBER:

DRAWING NUMBER:

**P910-872PT**

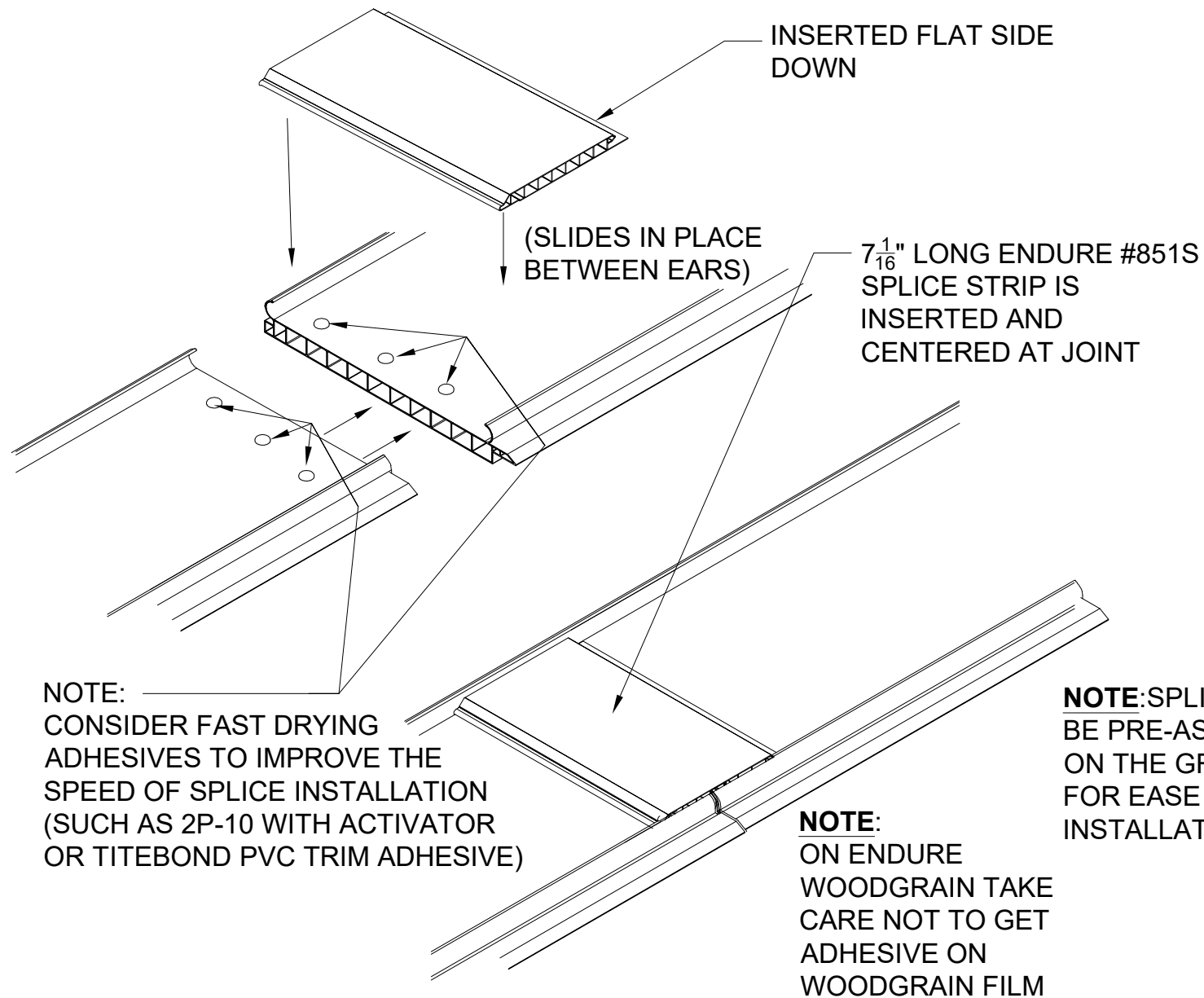

RULON INTERNATIONAL  
2000 Ring Way  
St. Augustine, FL 32092

(904) 584-1400  
info @ rulonco.com

www.rulonco.com

PROJECT:

TITLE: Endure#910 8" Integrated Spacer Strip #851S Splice Detail

ISSUE DATE:

REVISION DATE:  
APR/27/2026

DRAWN BY:

CAP

CHECKED BY:

MS/TR

PROJECT NUMBER:

DRAWING NUMBER:

P910-851

**CHANNEL STRUT  
CROSS-SECTION,  
TYPICAL**

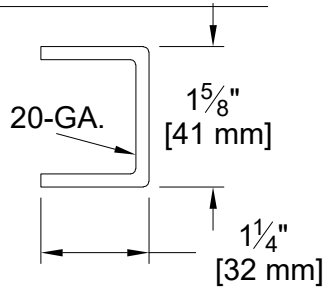

**#12 GA. HANGER WIRE  
CENTERS AS FOLLOWS:  
INTERIOR: 4' O.C. MAX  
(STRUTS OPTIONAL)  
EXTERIOR: 2' O.C. MAX  
(STRUTS REQUIRED)  
(6" MAX FROM ENDS)**

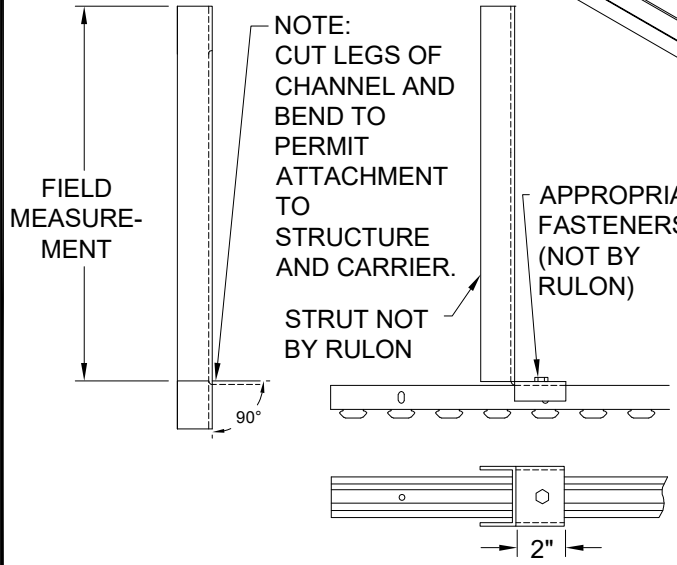
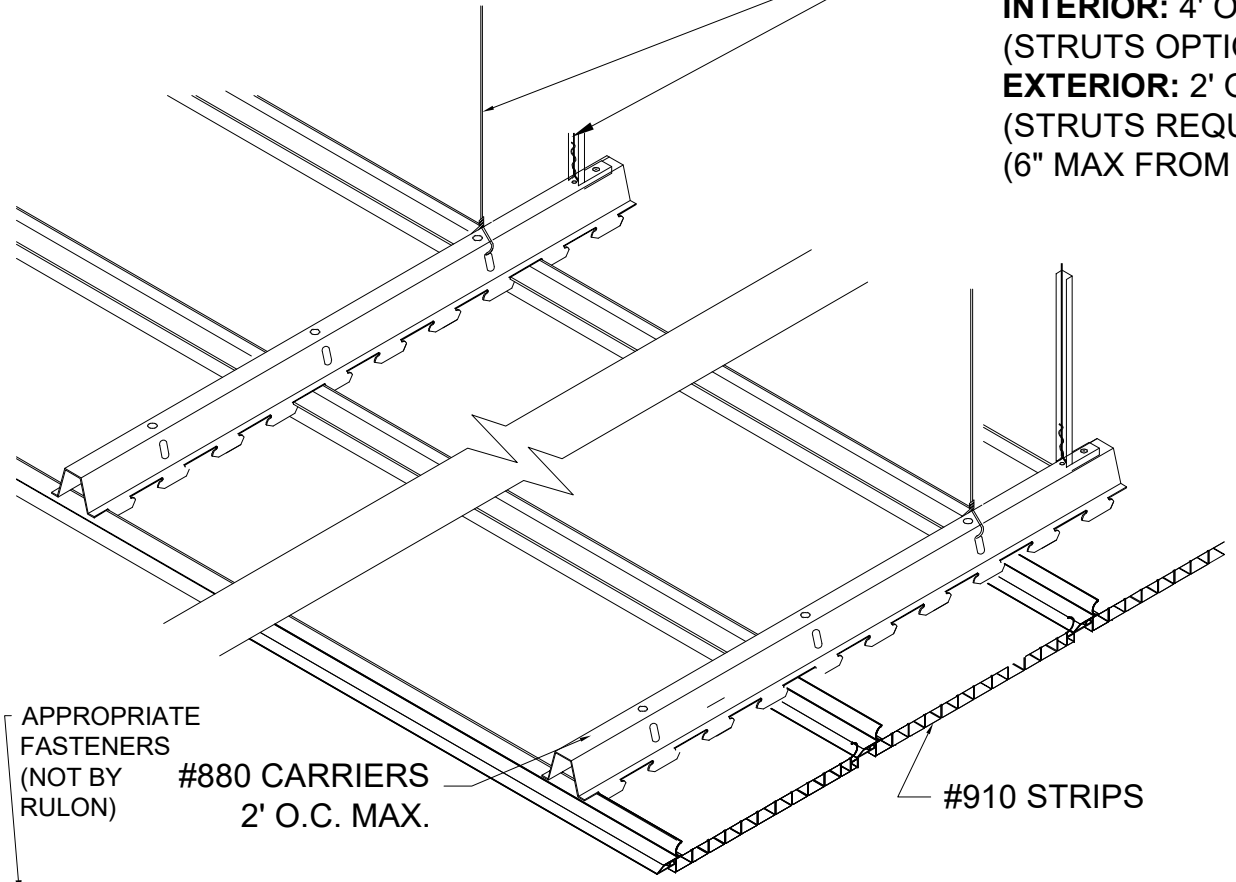

**#880 CARRIERS  
2' O.C. MAX.**

**#910 STRIPS**



RULON INTERNATIONAL  
2000 Ring Way  
St. Augustine, FL 32092  
  
(904) 584-1400  
info @ rulonco.com  
  
www.rulonco.com

PROJECT:

ISSUE DATE:

DRAWN BY:  
**CAP**

PROJECT NUMBER:

TITLE: **ENDURE™ Linear 910 Installation  
/ Spacing**

REVISION DATE:  
**DEC/15/2025**

CHECKED BY:  
**CMP**

DRAWING NUMBER:  
**P910-INSTALL**

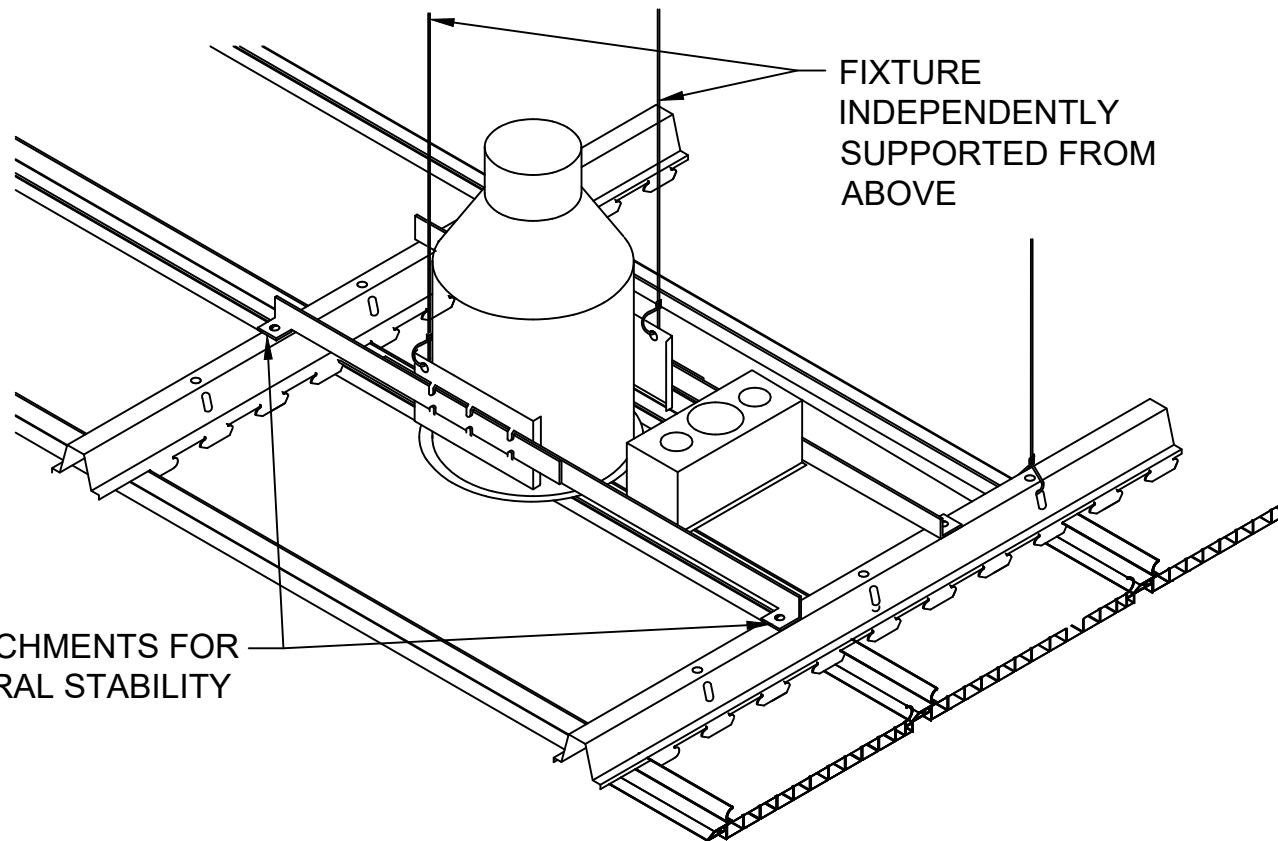

ATTACHMENTS FOR  
LATERAL STABILITY  
ONLY

FIXTURE  
INDEPENDENTLY  
SUPPORTED FROM  
ABOVE



RULON INTERNATIONAL  
2000 Ring Way  
St. Augustine, FL 32092

(904) 584-1400  
info @ rulonco.com

www.rulonco.com

PROJECT:

ISSUE DATE:

DRAWN BY:

PROJECT NUMBER:

CAP

TITLE: **ENDURE™ LINEAR#910 8"**  
Integrated Spacer  
Can Light Detail

REVISION DATE:

CHECKED BY:

DRAWING NUMBER:

DEC/07/2023

TR

P910-CLIGHT

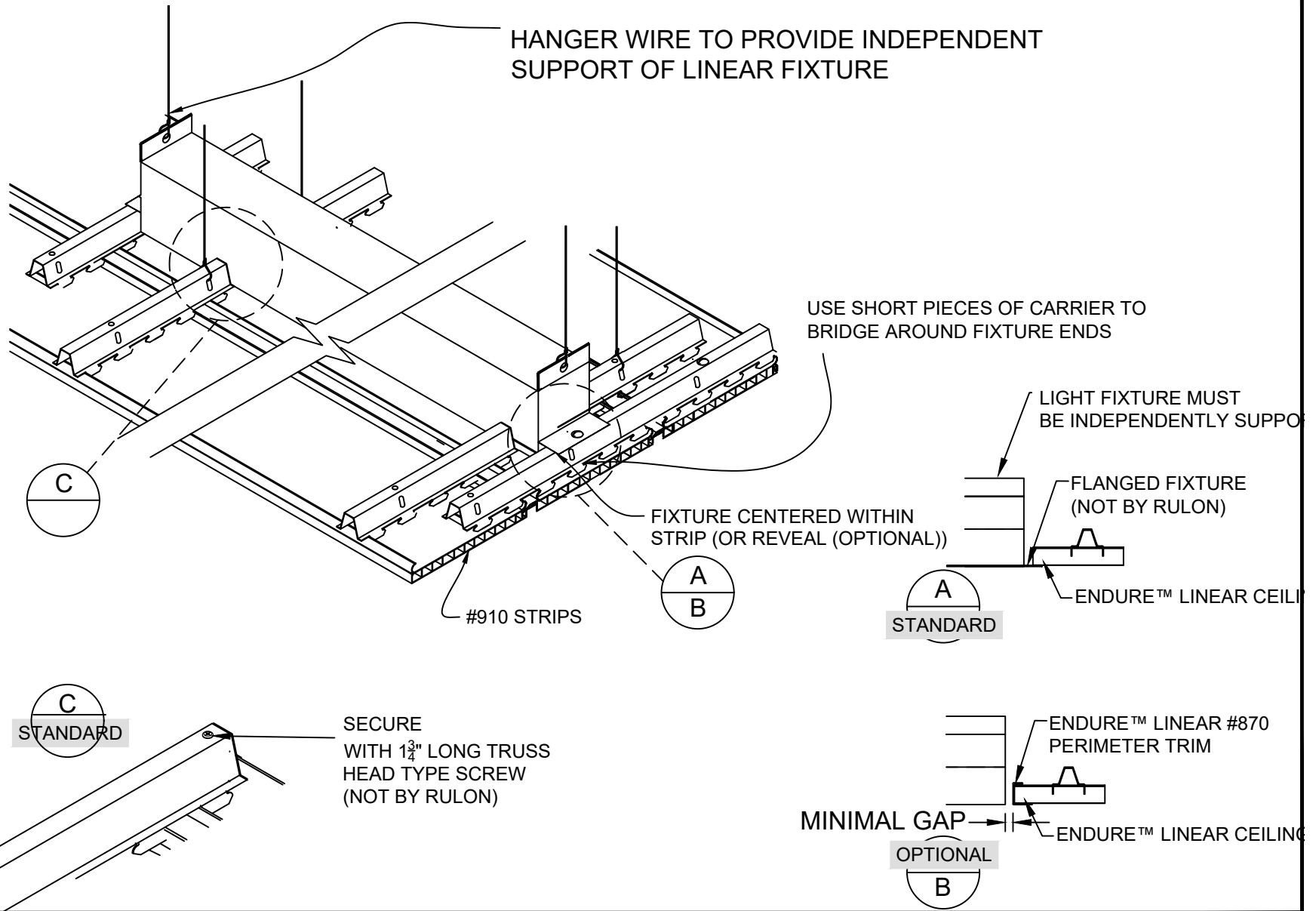

RULON INTERNATIONAL  
2000 Ring Way  
St. Augustine, FL 32092

(904) 584-1400  
info @ rulonco.com

www.rulonco.com

PROJECT:

TITLE: **ENDURE™ LINEAR#910 8"**  
Integrated Spacer  
Linear Fixture Detail

ISSUE DATE:

REVISION DATE:  
DEC/07/2023

DRAWN BY:

CAP

CHECKED BY:

TR

PROJECT NUMBER:

DRAWING NUMBER:

P910-LINF

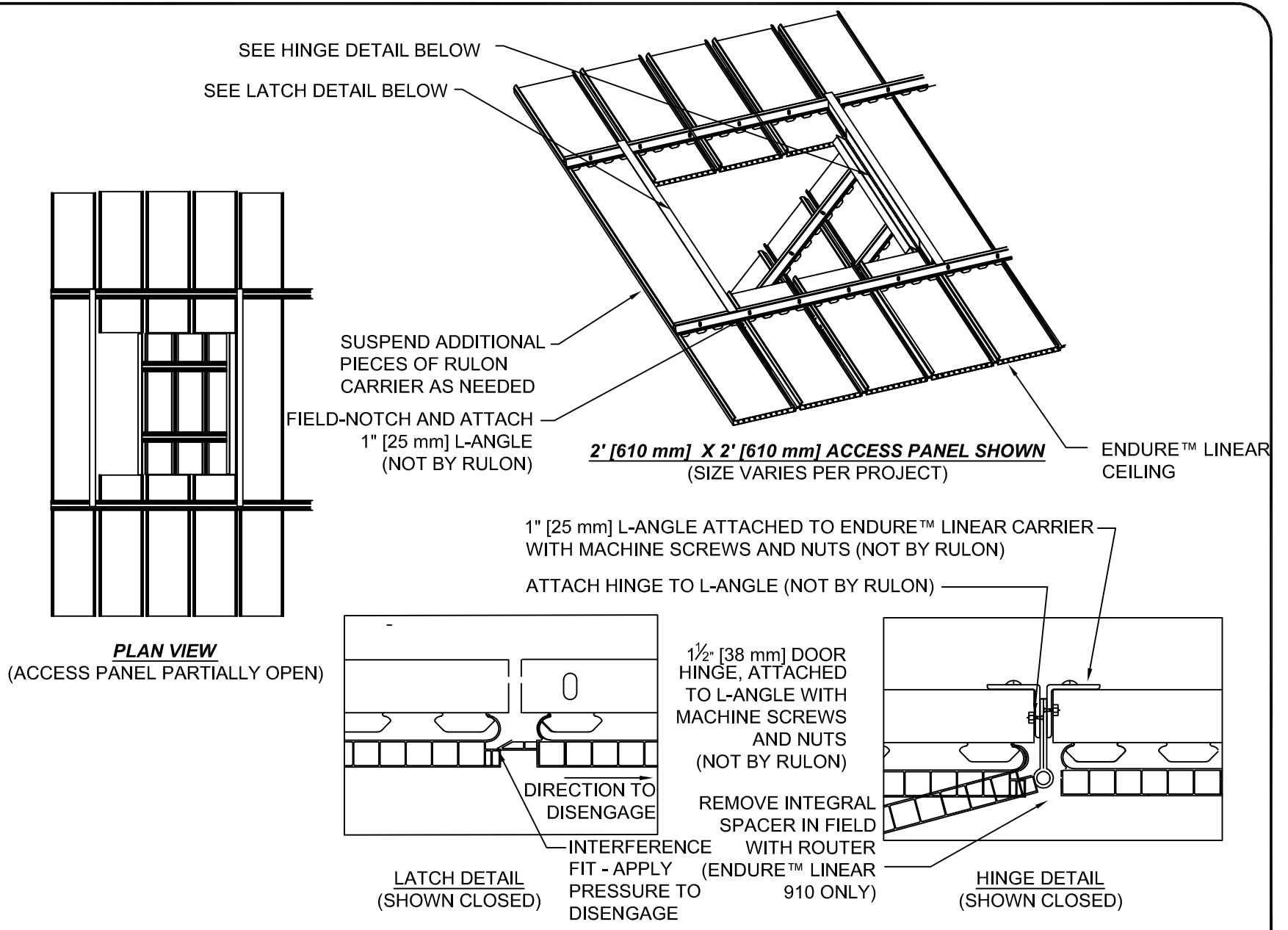

RULON INTERNATIONAL  
2000 Ring Way  
St. Augustine, FL 32092

(904) 584-1400  
info @ rulonco.com

www.rulonco.com

PROJECT:

ISSUE DATE:

DRAWN BY:

PROJECT NUMBER:

CAP

TITLE: **ENDURE™ LINEAR#910 8"**  
**Straight Edge**  
**Strip Access Panel Hinged**

REVISION DATE:

DEC/07/2023

CHECKED BY:

TR

DRAWING NUMBER:

P910AP-H