

<u>DRAWING #</u>	<u>TITLE</u>
P8000001	ENDURE #800 Profile - Straight Edge Strips
P8X0-EXTSEC	ENDURE #800 Series Exterior - Securing Spacer
P8000002	ENDURE #870 Perimeter Trim
P8000022	ENDURE #872 Floating 4" Trim
D-529	ENDURE #872 4" Trim Mitre Corner
P8900003	ENDURE #890 Carrier Connector
P8500004	ENDURE #850S Splice Material
P8000005	ENDURE #875 Expansion Joint
P9000006	ENDURE 800 Installation - Spacing
P8000008	ENDURE Recessed Can Light Detail
P8000009	ENDURE with Linear Light Fixture
P8000010	ENDURE 800 Access Panel Detail
P8X00012	ENDURE Linear Direct Mount Detail



RULON INTERNATIONAL
2000 Ring Way
St. Augustine, FL 32092

(904) 584-1400
info @ rulonco.com

www.rulonco.com

PROJECT:

TITLE: ENDURE™ 800 Index

ISSUE DATE:

REVISION DATE:
JAN/27/2026

DRAWN BY:

CAP

CHECKED BY:

CMP

PROJECT NUMBER:

DRAWING NUMBER:

P800-INDEX

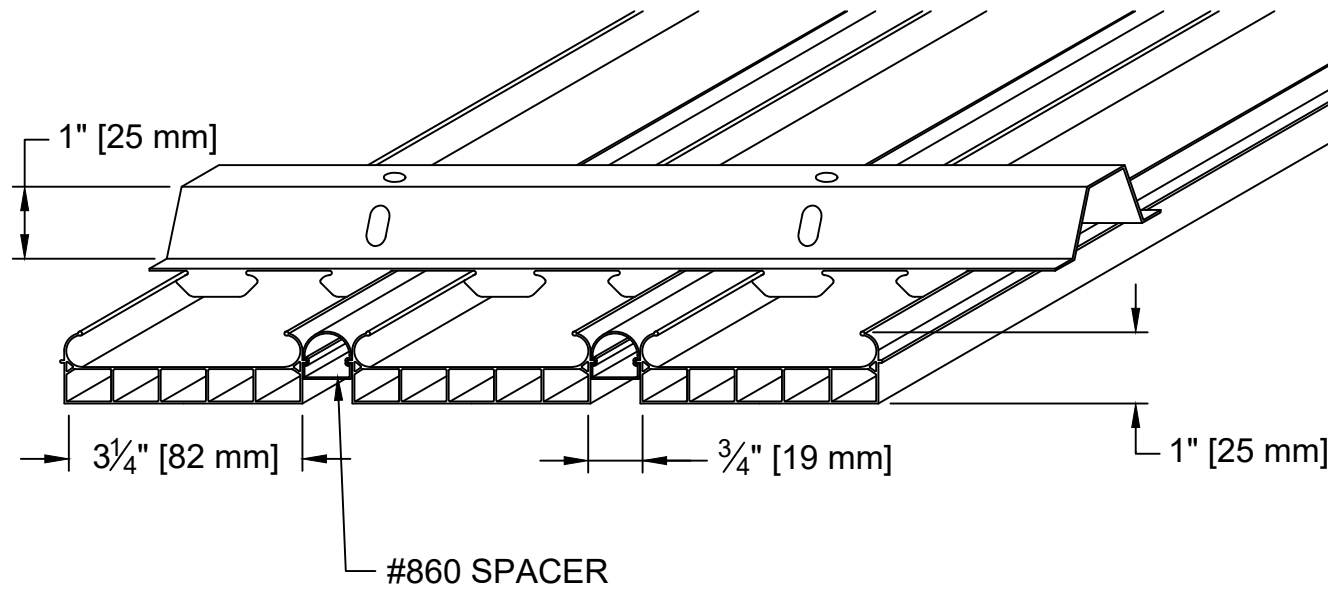

OPTION #1
WITH SPACER

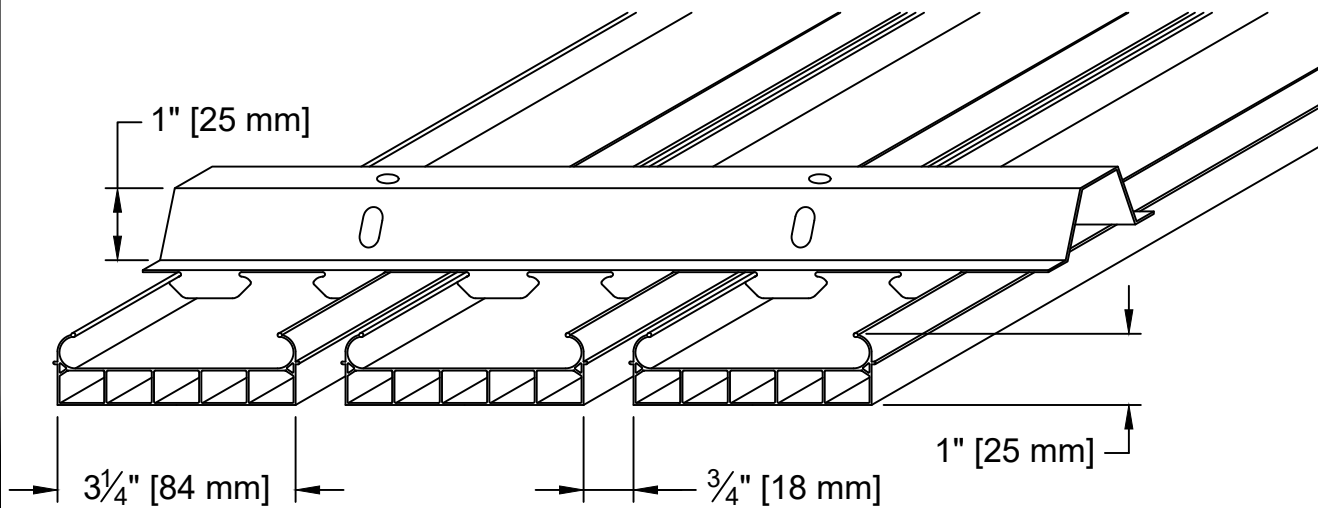

OPTION #2
WITHOUT SPACER



RULON INTERNATIONAL
2000 Ring Way
St. Augustine, FL 32092

(904) 584-1400
info @ rulonco.com

www.rulonco.com

PROJECT:

TITLE: **ENDURE™ LINEAR #800 Profile**
Straight Edge Strips

ISSUE DATE:

REVISION DATE:
MAR/14/2019

DRAWN BY:

CAP

CHECKED BY:

TR

PROJECT NUMBER:

DRAWING NUMBER:

P8000001

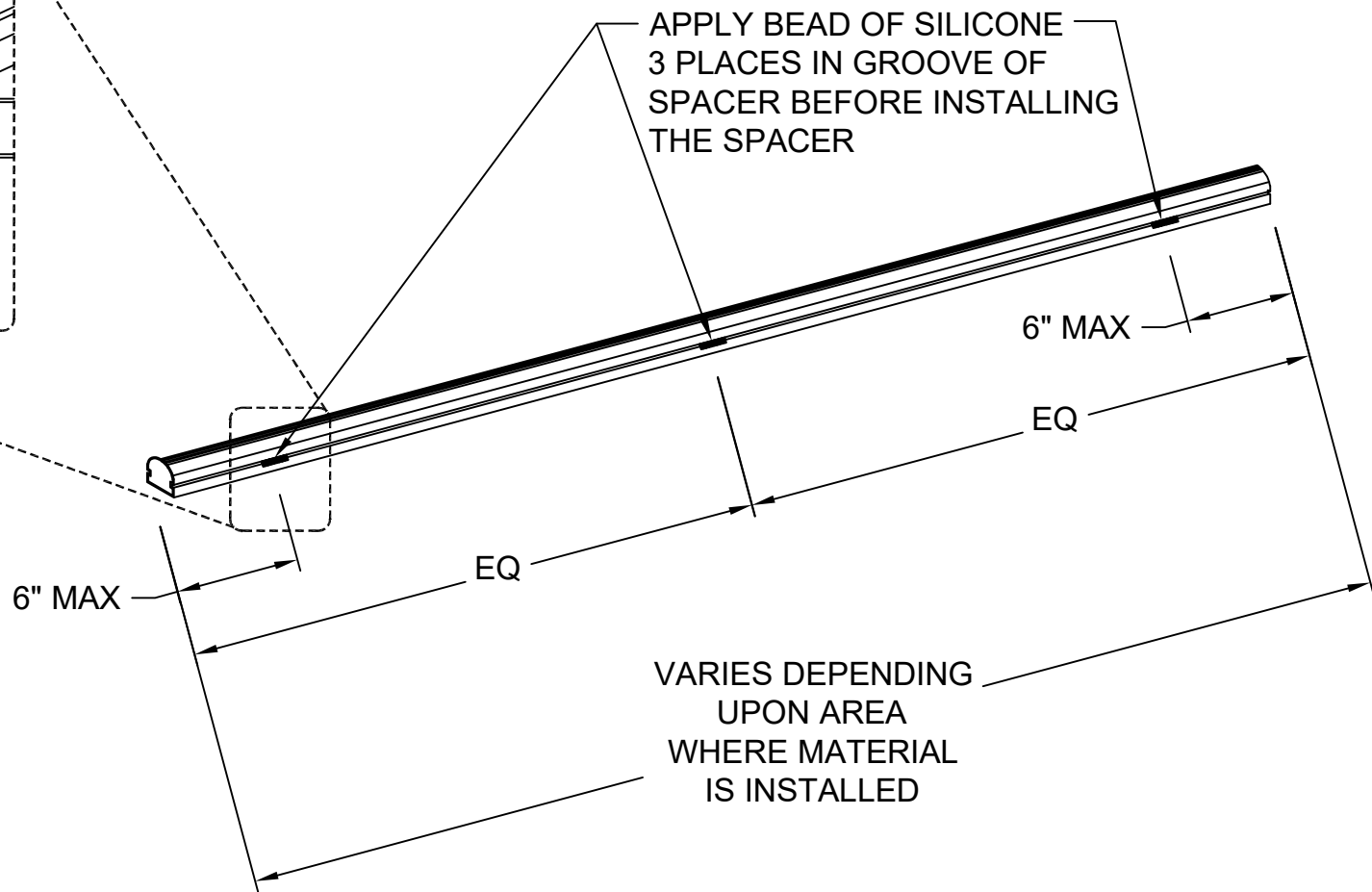
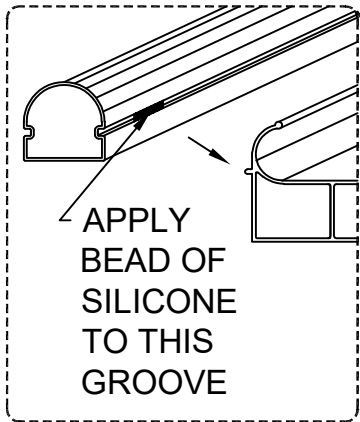

RULON INTERNATIONAL
2000 Ring Way
St. Augustine, FL 32092

(904) 584-1400
info @ rulonco.com

www.rulonco.com

PROJECT:

TITLE: **ENDURE™ 800 Series Exterior - Securing Spacer**

ISSUE DATE:

REVISION DATE:
JAN/27/2026

DRAWN BY:

CAP

CHECKED BY:

CMP

PROJECT NUMBER:

DRAWING NUMBER:
P8X0-EXTSEC

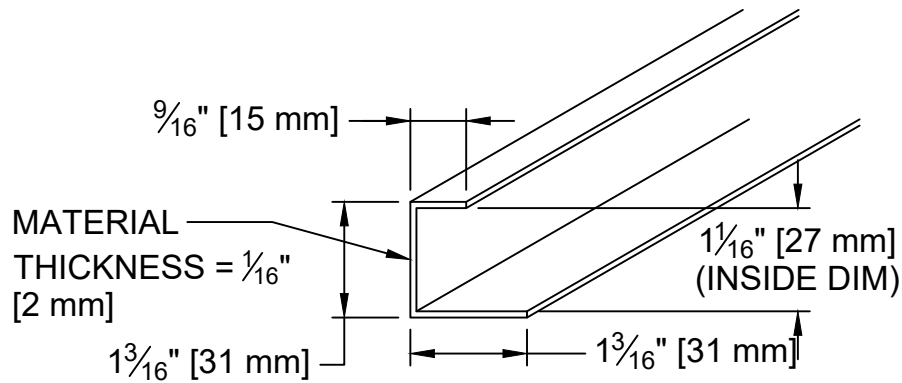
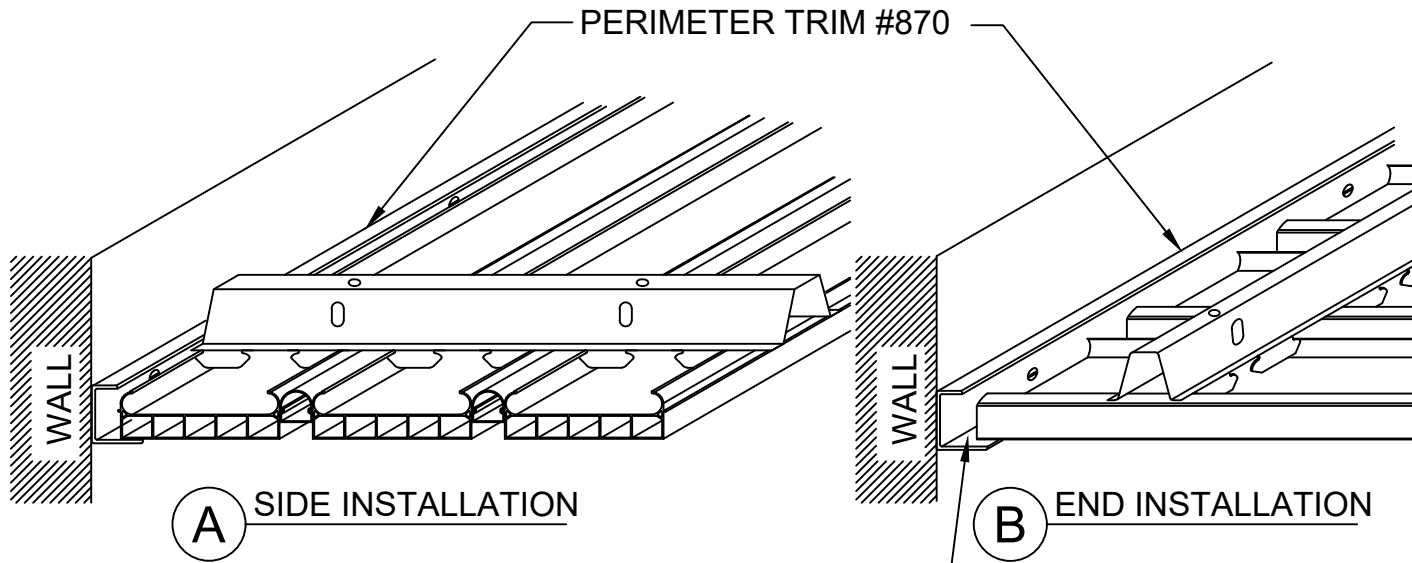

C #870 PERIMETER TRIM CROSS-SECTION



RULON INTERNATIONAL
2000 Ring Way
St. Augustine, FL 32092

(904) 584-1400
info @ rulonco.com

www.rulonco.com

PROJECT:

TITLE: ENDURE™ #870 Perimeter Trim

ISSUE DATE:

REVISION DATE:
DEC/15/2025

DRAWN BY:

CP

CHECKED BY:

CMP

PROJECT NUMBER:

DRAWING NUMBER:

P8000002

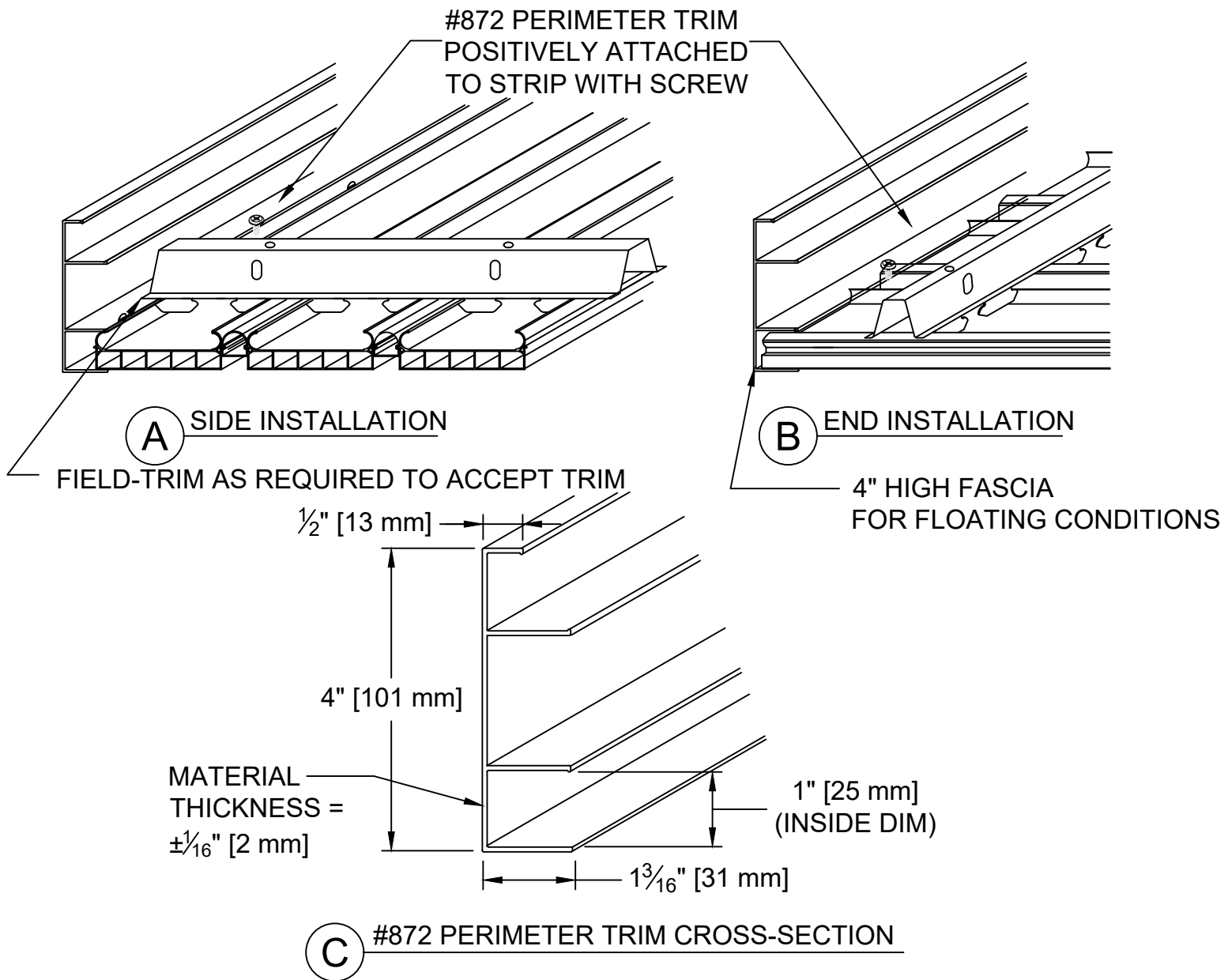

RULON INTERNATIONAL
2000 Ring Way
St. Augustine, FL 32092

(904) 584-1400
info @ rulonco.com

www.rulonco.com

PROJECT:

TITLE: **ENDURE™ 872 Floating 4" High Fascia**

ISSUE DATE:

REVISION DATE:
DEC/15/2025

DRAWN BY:

CAP

CHECKED BY:

CMP

PROJECT NUMBER:

DRAWING NUMBER:

P8000022

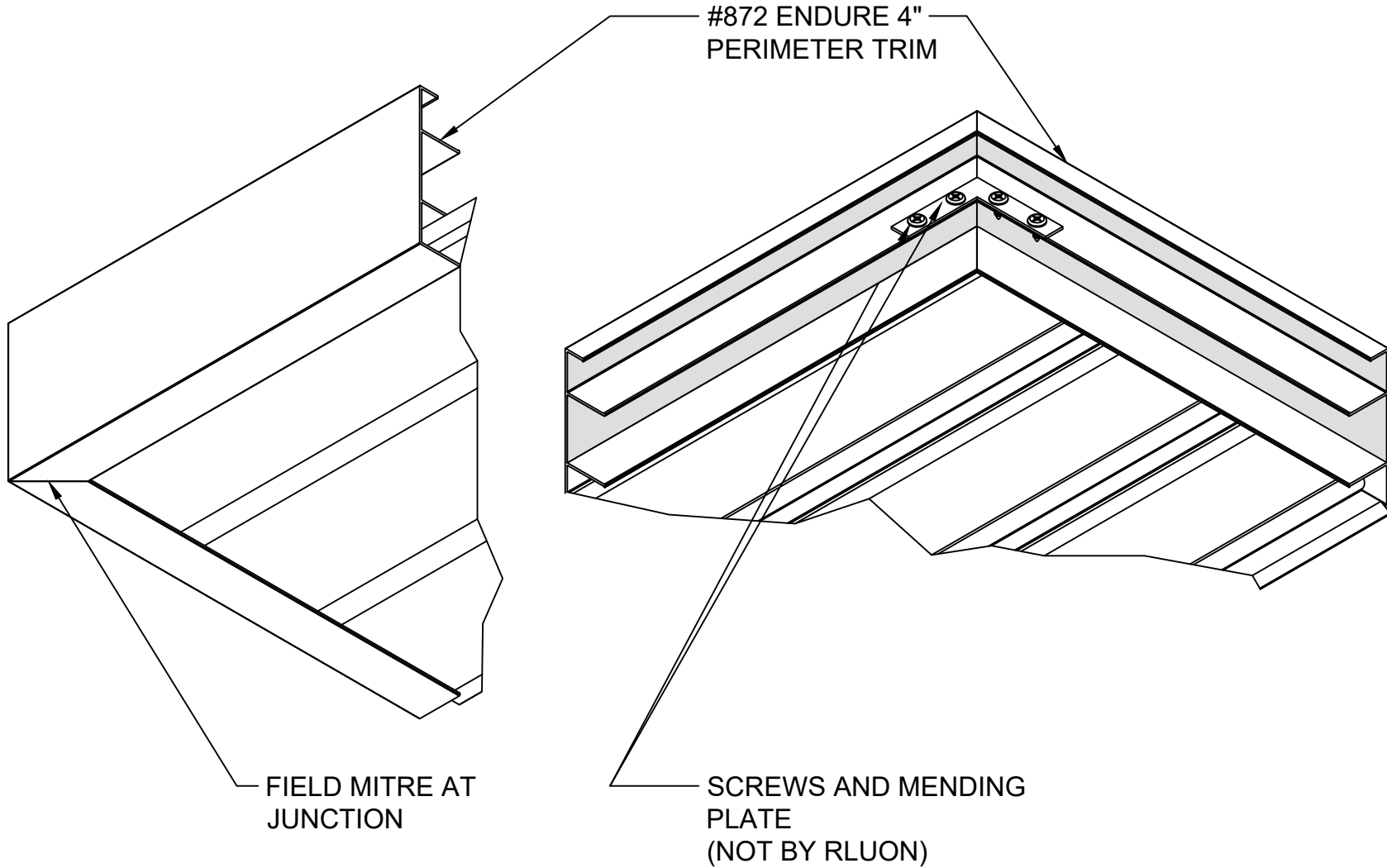

RULON INTERNATIONAL
 2000 Ring Way
 St. Augustine, FL 32092

(904) 584-1400
 info @ rulonco.com

www.rulonco.com

PROJECT:

TITLE: **Endure #872 4" Perimeter Trim
 Mitre Corner**

ISSUE DATE:

REVISION DATE:
MAR/16/2021

DRAWN BY:

CAP

CHECKED BY:

TR

PROJECT NUMBER:

DRAWING NUMBER:

D-529

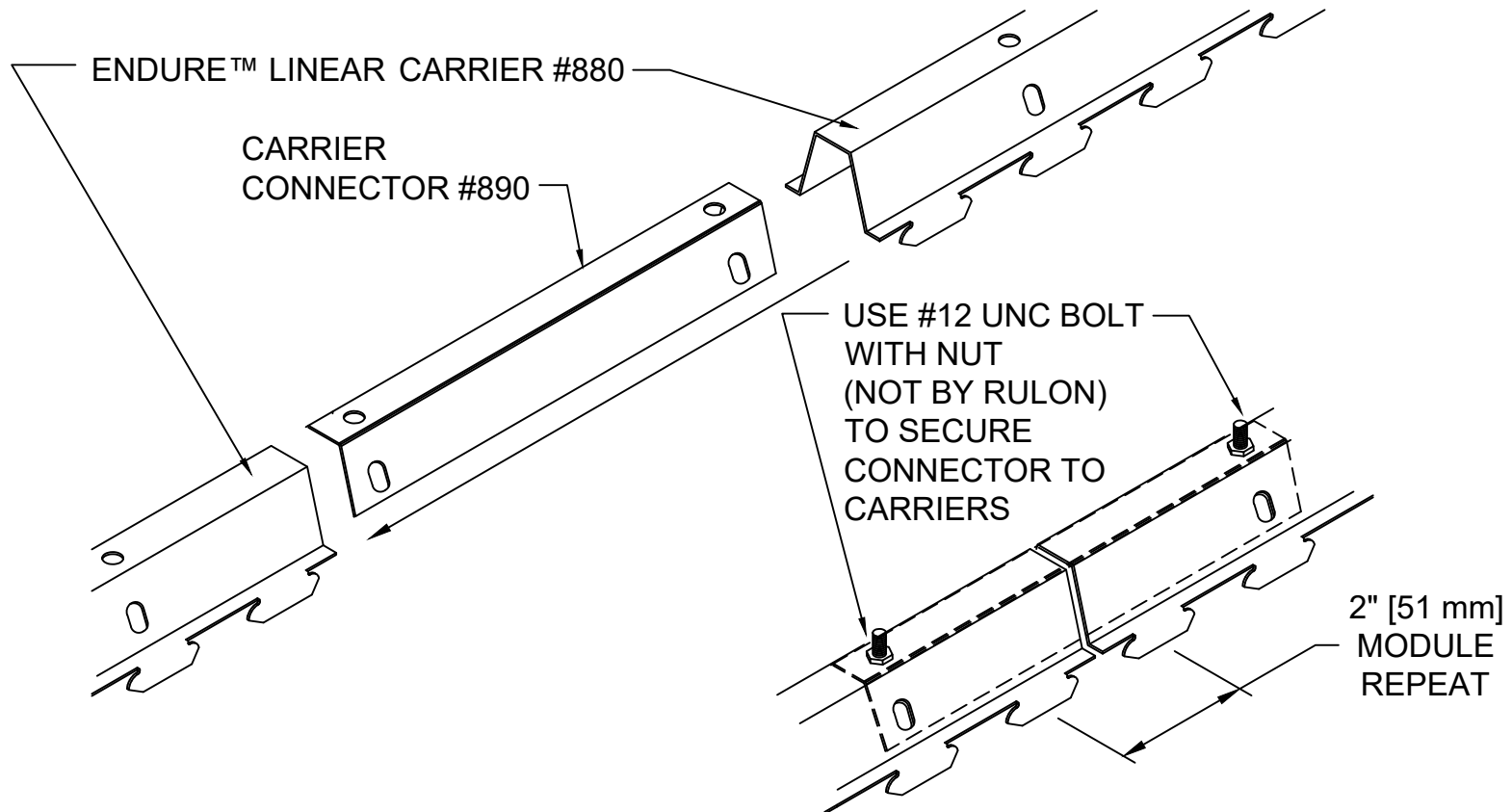

NOTE:
CARRIER CONNECTOR IS FOR
ALIGNMENT ONLY. SUPPORT
CARRIER AS NEEDED NEAR SPLICE.



RULON TIP

INSTALLATION TIP:
CARRIER CONNECTOR IS DESIGNED TO
BE POSITIONED INSIDE (AS SHOWN) OR
OUTSIDE OF THE CARRIER; ATTACHED
THROUGH HOLES IN TOP (AS SHOWN)
OR SIDES



RULON INTERNATIONAL
2000 Ring Way
St. Augustine, FL 32092

(904) 584-1400
info @ rulonco.com

www.rulonco.com

PROJECT:

TITLE: **ENDURE™ LINEAR #890 Carrier
Connector**

ISSUE DATE:

REVISION DATE:
DEC/15/2025

DRAWN BY:

CAP

CHECKED BY:

CMP

PROJECT NUMBER:

DRAWING NUMBER:

P8900003

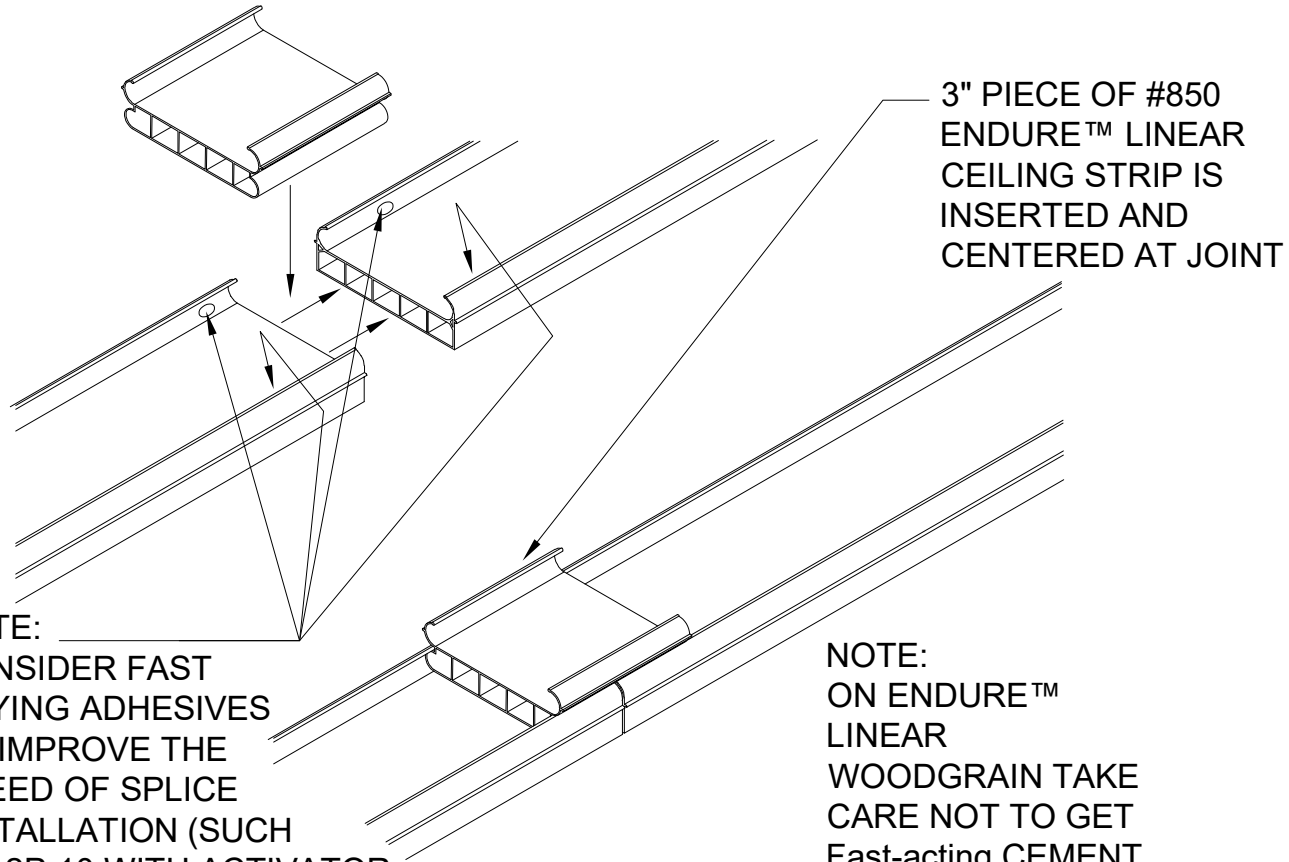

NOTE:
 CONSIDER FAST DRYING ADHESIVES TO IMPROVE THE SPEED OF SPLICE INSTALLATION (SUCH AS 2P-10 WITH ACTIVATOR OR TITEBOND PVC TRIM ADHESIVE)

NOTE:
 ON ENDURE™ LINEAR WOODGRAIN TAKE CARE NOT TO GET Fast-acting CEMENT ON WOODGRAIN FILM



RULON INTERNATIONAL
 2000 Ring Way
 St. Augustine, FL 32092

(904) 584-1400
 info @ rulonco.com

www.rulonco.com

PROJECT:

TITLE: **ENDURE™ LINEAR #850S**
 Splice Material

ISSUE DATE:

REVISION DATE:
APR/27/2026

DRAWN BY:

CAP

CHECKED BY:

MS/TR

PROJECT NUMBER:

DRAWING NUMBER:

P8000004

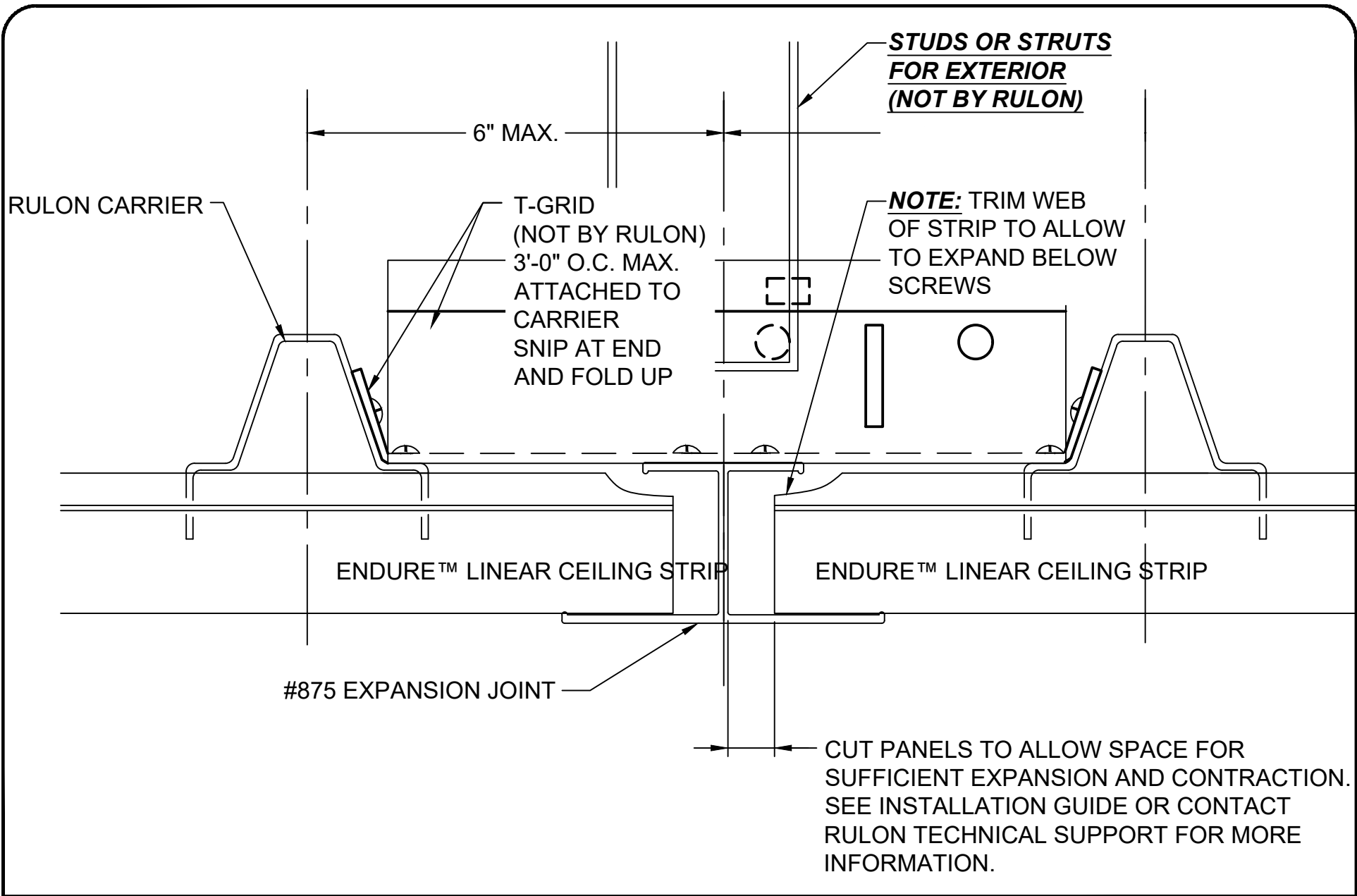

RULON INTERNATIONAL
2000 Ring Way
St. Augustine, FL 32092

(904) 584-1400
info @ rulonco.com

www.rulonco.com

PROJECT:

TITLE: **ENDURE™ LINEAR #875**
Expansion Joint Detail

ISSUE DATE:

REVISION DATE:
DEC/15/2025

DRAWN BY:

CAP

CHECKED BY:

CMP

PROJECT NUMBER:

DRAWING NUMBER:

P8000005

CHANNEL STRUT CROSS-SECTION, TYPICAL

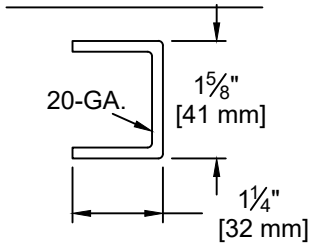

**#12 GA. HANGER WIRE CENTERS AS FOLLOWS:
 INTERIOR: 4' O.C. MAX (STRUTS OPTIONAL)
 EXTERIOR: 2' O.C. MAX (STRUTS REQUIRED)**

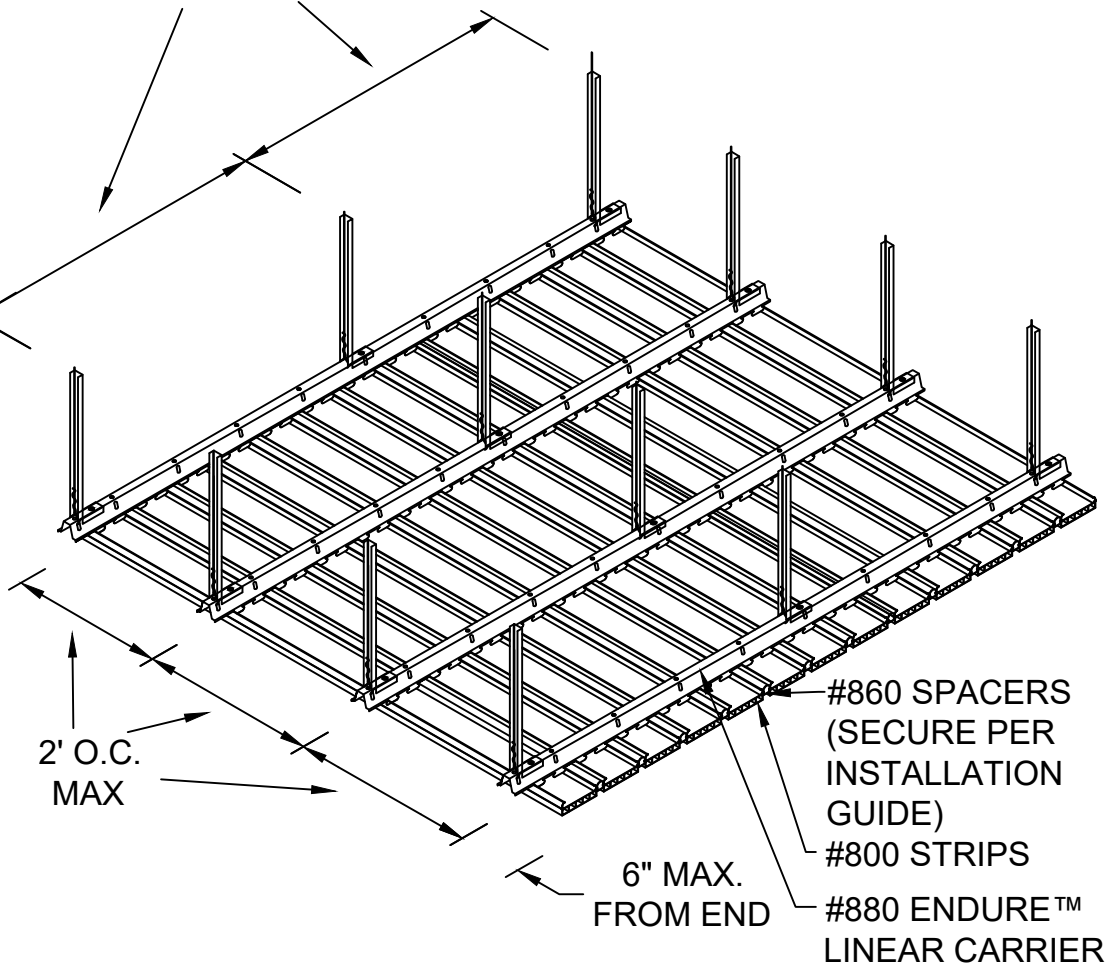

6" MAX FROM END

2' O.C. MAX

6" MAX. FROM END

#860 SPACERS (SECURE PER INSTALLATION GUIDE)
 #800 STRIPS
 #880 ENDURE™ LINEAR CARRIER

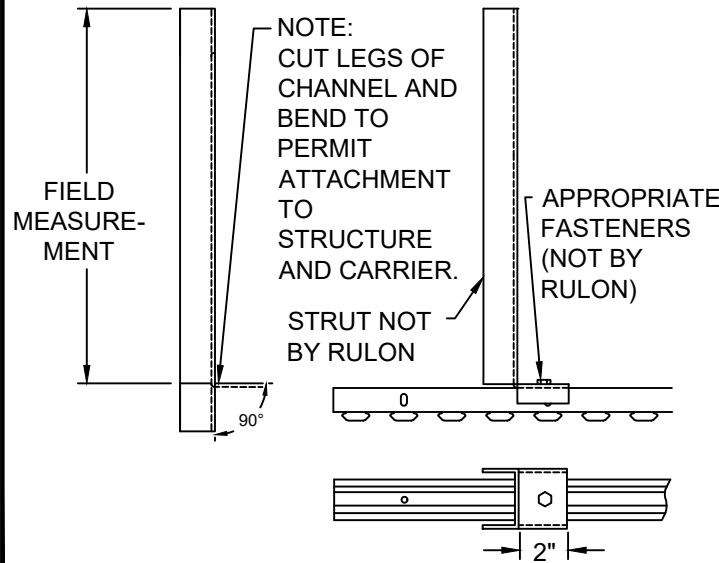

TYPICAL STRUT

 <p>RULON INTERNATIONAL 2000 Ring Way St. Augustine, FL 32092 (904) 584-1400 info@rulonco.com www.rulonco.com</p>	PROJECT:	ISSUE DATE:	DRAWN BY:	PROJECT NUMBER:
	TITLE: ENDURE™ LINEAR 800 Installation - Spacing	REVISION DATE: DEC/15/2025	CHECKED BY: CMP	DRAWING NUMBER: P8000006

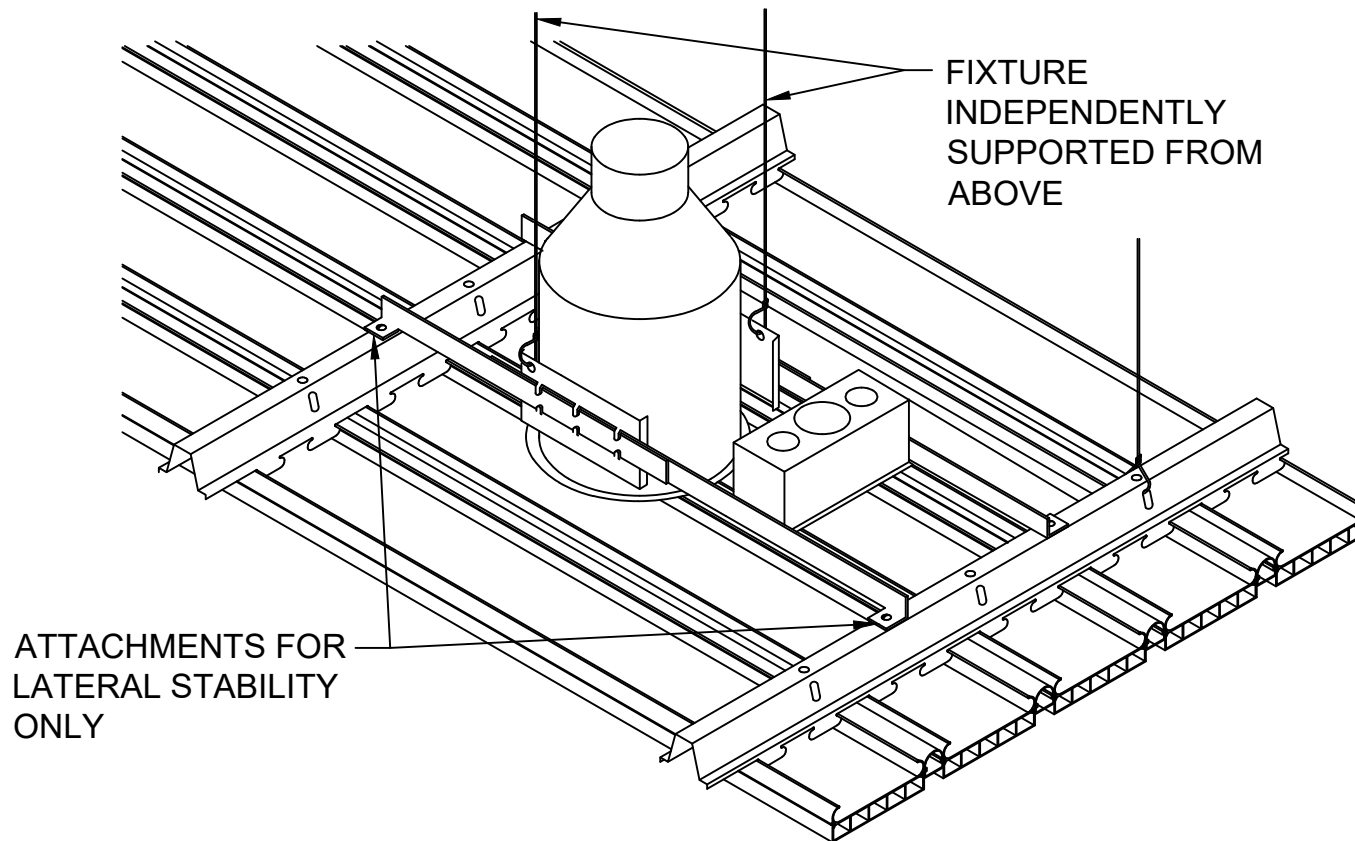

ATTACHMENTS FOR
LATERAL STABILITY
ONLY

FIXTURE
INDEPENDENTLY
SUPPORTED FROM
ABOVE



RULON INTERNATIONAL
2000 Ring Way
St. Augustine, FL 32092

(904) 584-1400
info @ rulonco.com

www.rulonco.com

PROJECT:

TITLE: **ENDURE™ LINEAR Recessed
Can Light Detail**

ISSUE DATE:

REVISION DATE:
DEC/15/2025

DRAWN BY:

CAP

CHECKED BY:

CMP

PROJECT NUMBER:

DRAWING NUMBER:

P8000008

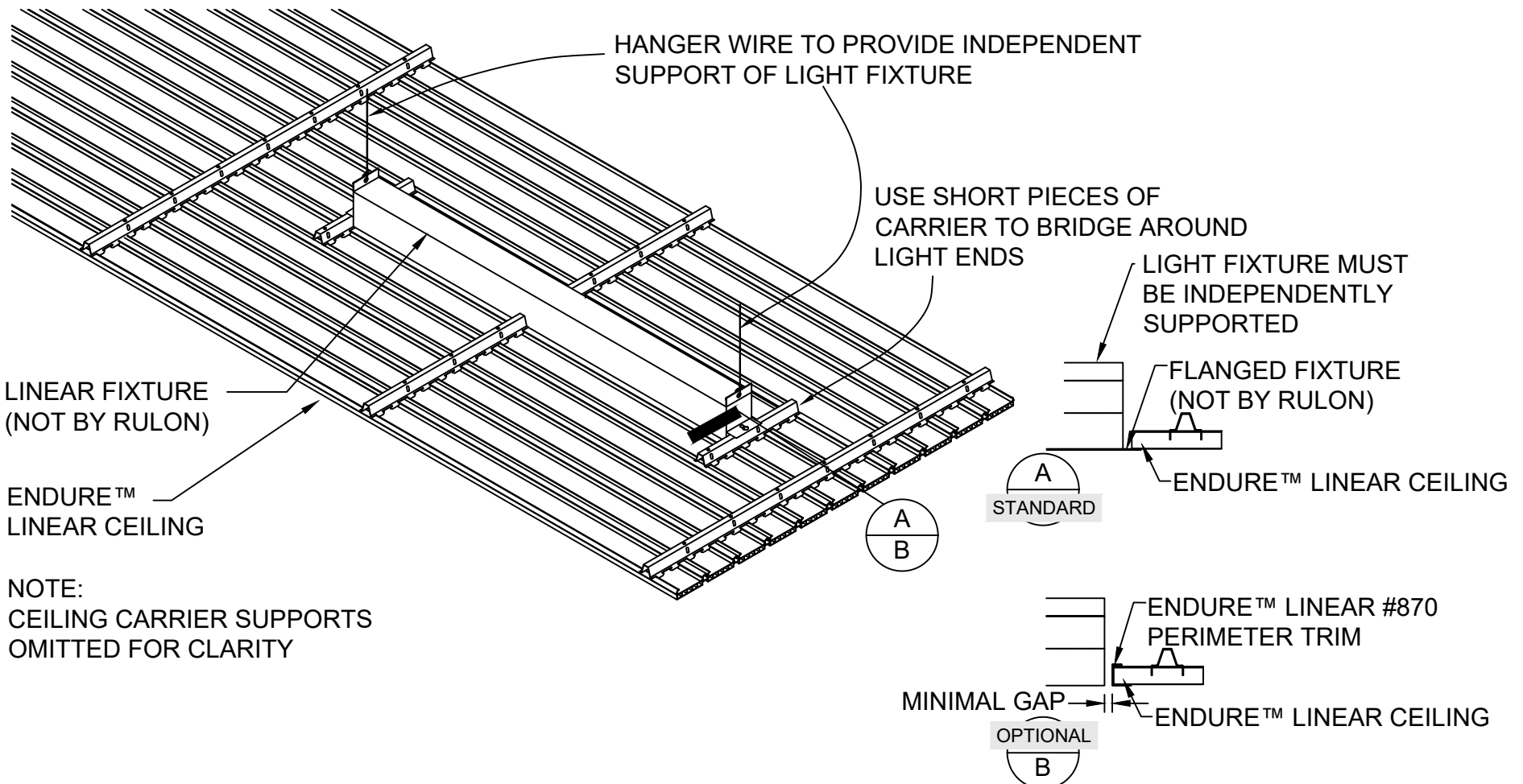

RULON INTERNATIONAL
2000 Ring Way
St. Augustine, FL 32092

(904) 584-1400
info @ rulonco.com

www.rulonco.com

PROJECT:

TITLE: **ENDURE™ with Linear Light
Fixture**

ISSUE DATE:

REVISION DATE:
DEC/15/2025

DRAWN BY:

CAP

CHECKED BY:

CMP

PROJECT NUMBER:

DRAWING NUMBER:

P8000009

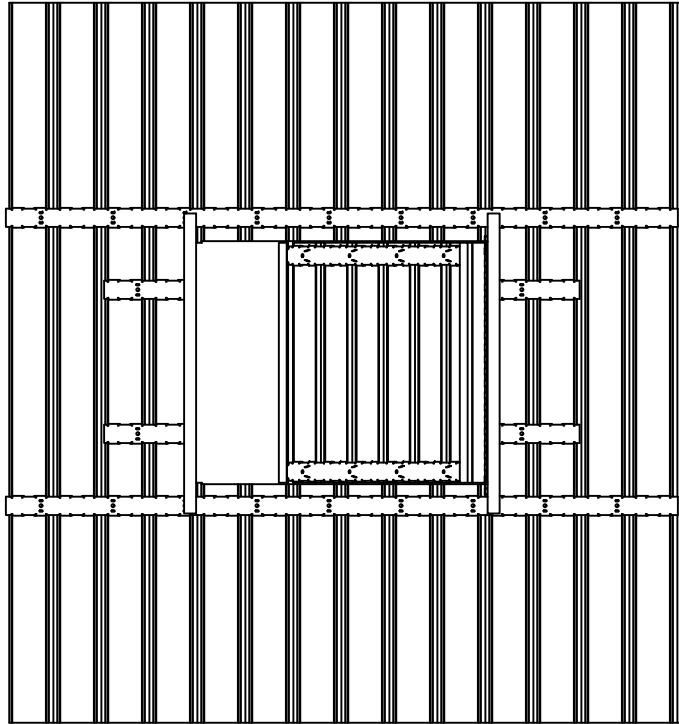

PLAN VIEW

(ACCESS PANEL PARTIALLY OPEN)
 BOLT/WASHER AND WING NUT
 (NOT BY RULON) MINIMUM 2 PLACES
 ALONG L-LANGLE

REMOVE
 SPACER IF APPLICABLE
 AND ADJACENT STRIP
 FOR ACCESS TO WING NUT
 (ENDURE™ LINEAR 800 ONLY)

SEE HINGE DETAIL BELOW
 SEE LATCH DETAIL BELOW

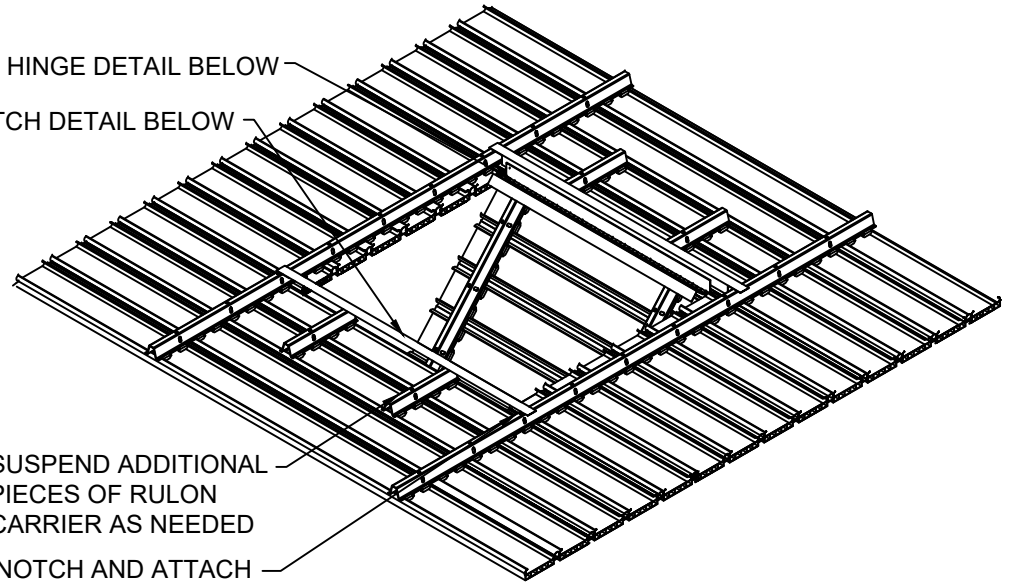

SUSPEND ADDITIONAL
 PIECES OF RULON
 CARRIER AS NEEDED
 FIELD-NOTCH AND ATTACH
 1" [25 mm] L-ANGLE
 (NOT BY RULON)

NOM. 2' X 2' ACCESS PANEL SHOWN
 (SIZE VARIES PER PROJECT)

1" [25 mm] L-ANGLE ATTACHED TO ENDURE™ LINEAR CARRIER
 WITH MACHINE SCREWS AND NUTS (NOT BY RULON)
 HARDWARE TO SUPPORT MATERIAL WEIGHT OF 1.6LB/SF
 ATTACH HINGE TO L-ANGLE (NOT BY RULON)

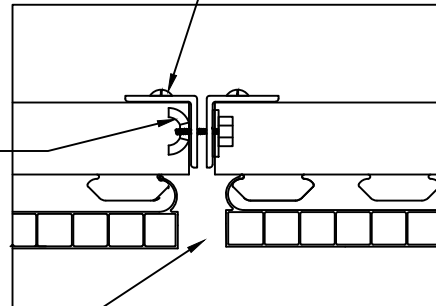

LATCH DETAIL
 (SHOWN CLOSED)

INTERFERENCE
 FIT - APPLY
 PRESSURE TO
 DISENGAGE

1/2" [38 mm] DOOR
 HINGE, ATTACHED
 TO L-ANGLE WITH
 MACHINE SCREWS
 AND NUTS
 (NOT BY RULON)

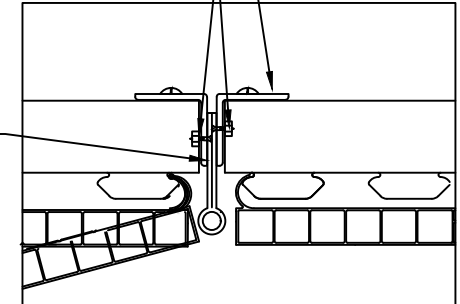

HINGE DETAIL
 (SHOWN CLOSED)



RULON INTERNATIONAL
 2000 Ring Way
 St. Augustine, FL 32092

(904) 584-1400
 info @ rulonco.com

www.rulonco.com

PROJECT:

ISSUE DATE:

DRAWN BY:

PROJECT NUMBER:

CAP

TITLE: **ENDURE™ 800 Access Panel
 Detail**

REVISION DATE:
DEC/15/2025

CHECKED BY:
CMP

DRAWING NUMBER:
P8000010

SHIM UNDER STUDS/STRUCTURE WHERE NECESSARY TO LEVEL THE CARRIERS

METAL STUDS OR STRUCTURE (NOT BY RULON)

METAL STUD

SHIM

#880 CARRIER

#880 CARRIER

ATTACH #880 CARRIER TO METAL STUDS /STRUCTURE USING SCREWS 2' ON CENTER** (NOT BY RULON)

**WHEN ATTACHING TO PLYWOOD SHEATHING/FURRING USE SCREWS 1' O.C. TYPICAL



RULON INTERNATIONAL
 2000 Ring Way
 St. Augustine, FL 32092
 (904) 584-1400
 info @ rulonco.com
 www.rulonco.com

PROJECT:

ISSUE DATE:

DRAWN BY:
CAP

PROJECT NUMBER:

TITLE: **ENDURE™ LINEAR Direct Mount Detail**

REVISION DATE:
DEC/17/2025

CHECKED BY:
CMP

DRAWING NUMBER:
P8X00012