

<u>DRAWING #</u>	<u>TITLE</u>	<u>DRAWING #</u>	<u>TITLE</u>
P9000001	ENDURE #900 Profile		
P9000002	ENDURE #870 Perimeter Trim		
P9000022	ENDURE #872 Floating 4" Trim		
PXX00003	ENDURE #890 Carrier Connector		
P8500004	ENDURE #850S Splice Material		
P9000005	ENDURE #875 Expansion Joint		
P9000006	ENDURE 900 Installation - Spacing		
P9000008	ENDURE Recessed Can Light Detail		
P9000009	ENDURE Linear Light Fixture		
P9000010	ENDURE Access Panel Detail		
PXX00012	ENDURE Direct Mount Detail		



RULON INTERNATIONAL  
 2000 Ring Way  
 St. Augustine, FL 32092

(904) 584-1400  
 info @ rulonco.com

www.rulonco.com

PROJECT:

TITLE: ENDURE 900 Index

ISSUE DATE:

REVISION DATE:  
 DEC/15/2025

DRAWN BY:

CAP

CHECKED BY:

CMP

PROJECT NUMBER:

DRAWING NUMBER:

P900-INDEX

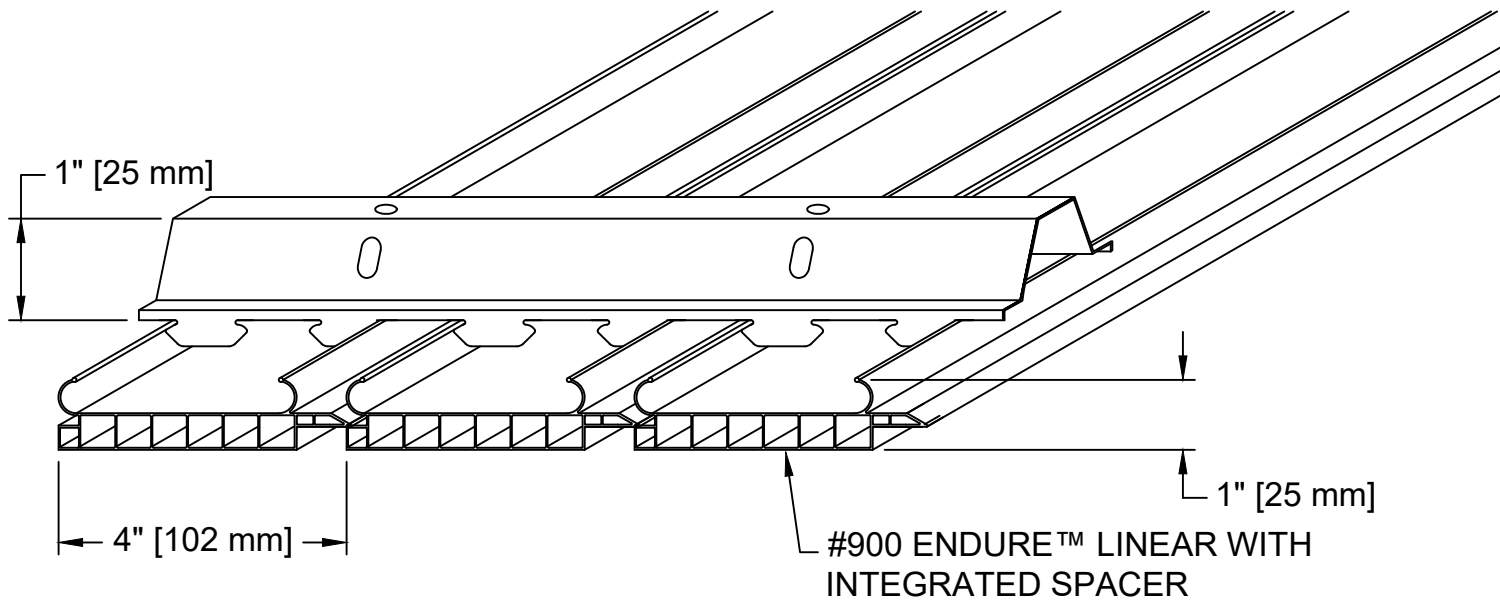

RULON INTERNATIONAL  
 2000 Ring Way  
 St. Augustine, FL 32092

(904) 584-1400  
 info @ rulonco.com

www.rulonco.com

PROJECT:

TITLE: ENDURE™ LINEAR #900 Profile

ISSUE DATE:

REVISION DATE:  
 MAR/14/2019

DRAWN BY:

CAP

CHECKED BY:

TR

PROJECT NUMBER:

DRAWING NUMBER:

P9000001

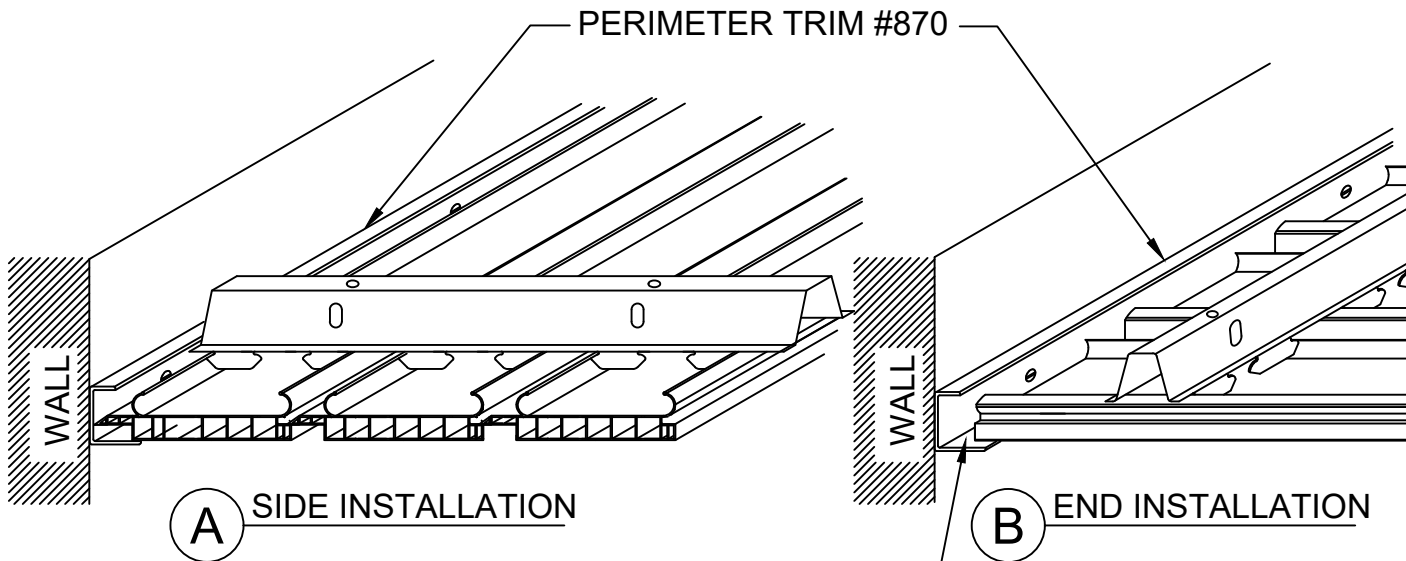

NOTE:  
ALLOW SUFFICIENT SPACE FOR EXPANSION  
AT PERIMETER. SEE INSTALLATION GUIDE  
FOR MORE INFORMATION

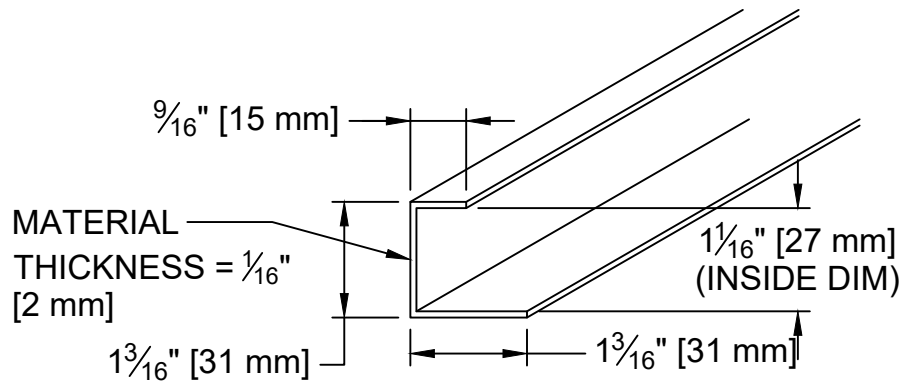

**C** #870 PERIMETER TRIM CROSS-SECTION



RULON INTERNATIONAL  
2000 Ring Way  
St. Augustine, FL 32092

(904) 584-1400  
info @ rulonco.com

www.rulonco.com

PROJECT:

TITLE: ENDURE™ #870 Perimeter Trim

ISSUE DATE:

REVISION DATE:  
OCT/13/2023

DRAWN BY:

CP

CHECKED BY:

TDA

PROJECT NUMBER:

DRAWING NUMBER:

P9000002

#872 ENDURE™ LINEAR 4"  
PERIMETER TRIM

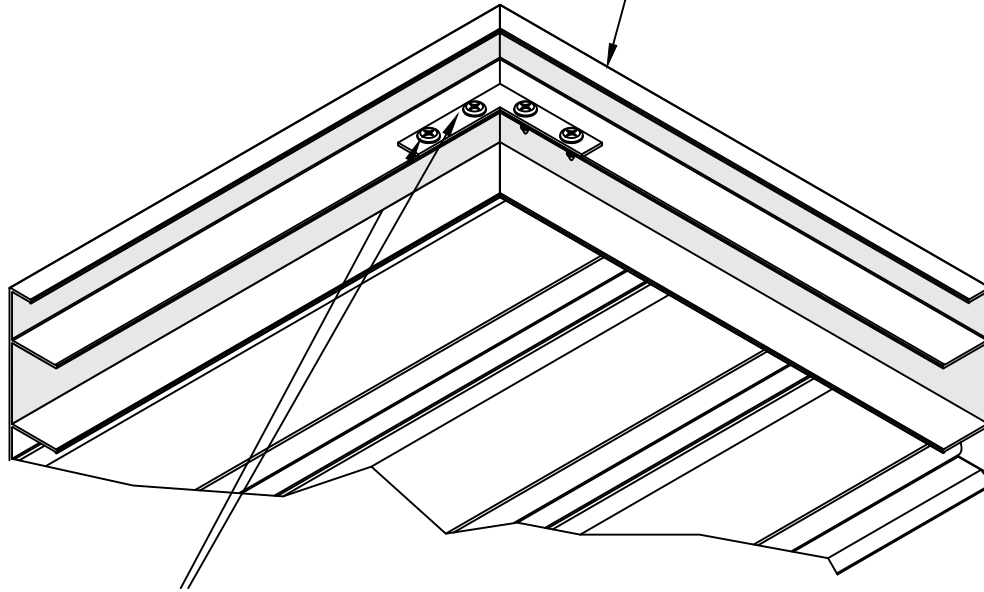

RULON INTERNATIONAL  
2000 Ring Way  
St. Augustine, FL 32092

(904) 584-1400  
info @ rulonco.com

www.rulonco.com

PROJECT:

TITLE: **ENDURE™ Double Stack  
Perimeter Trim**

ISSUE DATE:

REVISION DATE:  
**MAR/14/2019**

DRAWN BY:

**CAP**

CHECKED BY:

**TR**

PROJECT NUMBER:

DRAWING NUMBER:

**P9000021**

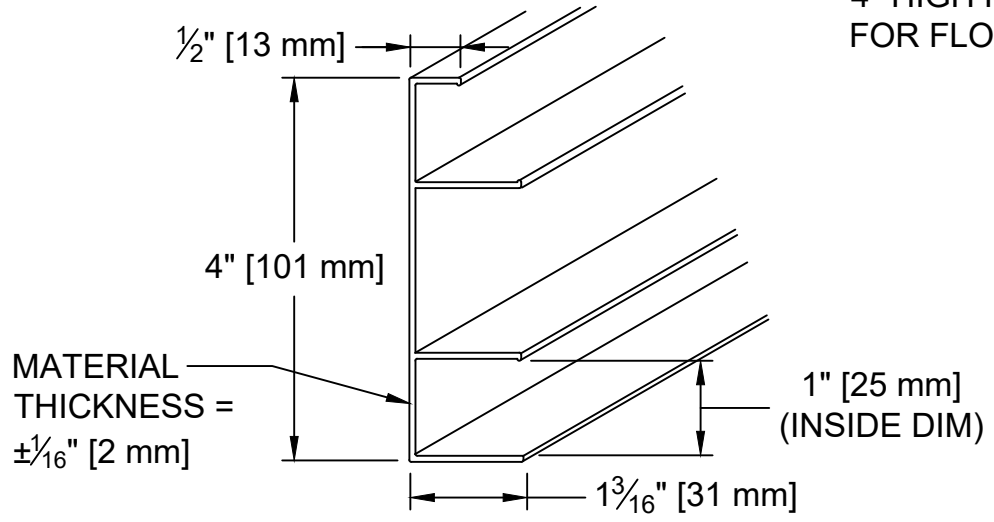
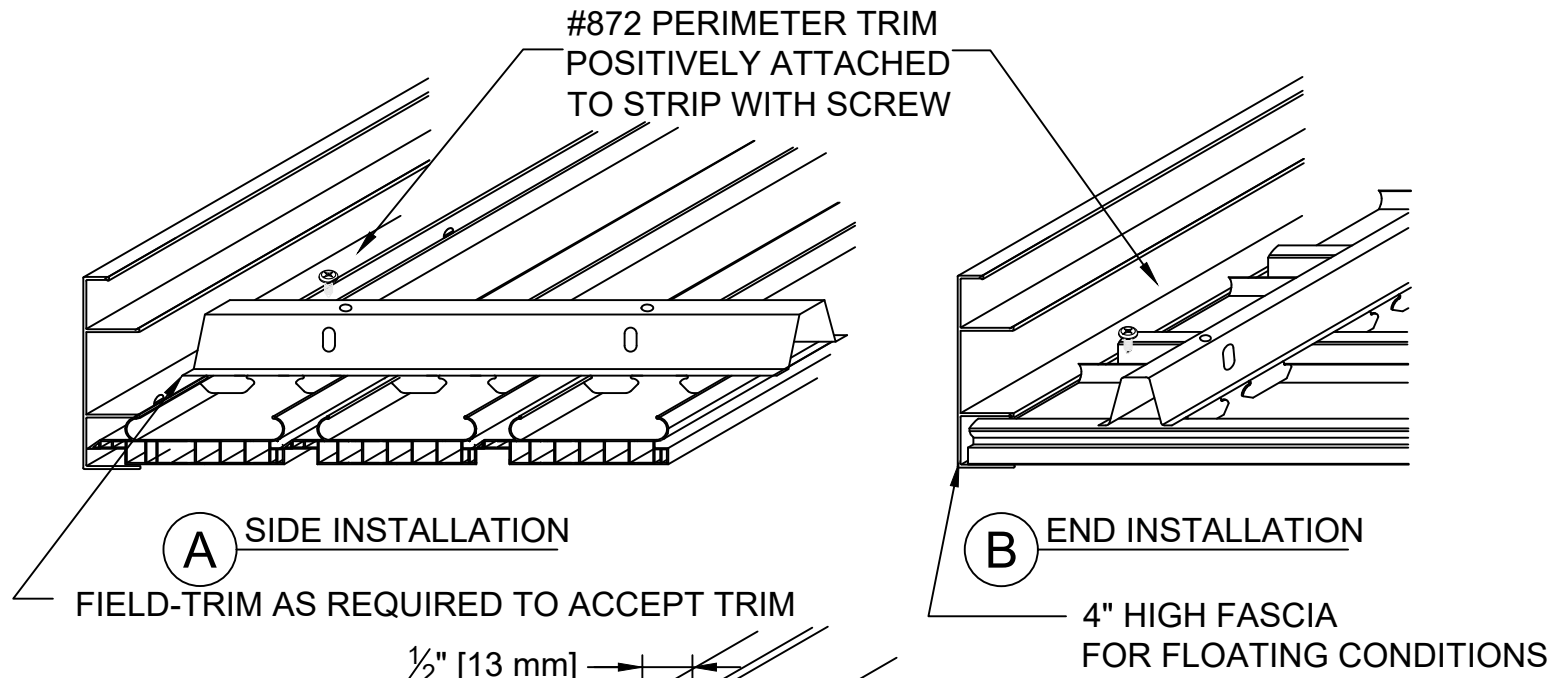

RULON INTERNATIONAL  
2000 Ring Way  
St. Augustine, FL 32092  
  
(904) 584-1400  
info @ rulonco.com  
  
www.rulonco.com

PROJECT:	ISSUE DATE:	DRAWN BY: <b>CAP</b>	PROJECT NUMBER:
TITLE: <b>ENDURE™ 872 Floating 4" High Fascia</b>	REVISION DATE: <b>MAR/14/2019</b>	CHECKED BY: <b>TR</b>	DRAWING NUMBER: <b>P9000022</b>

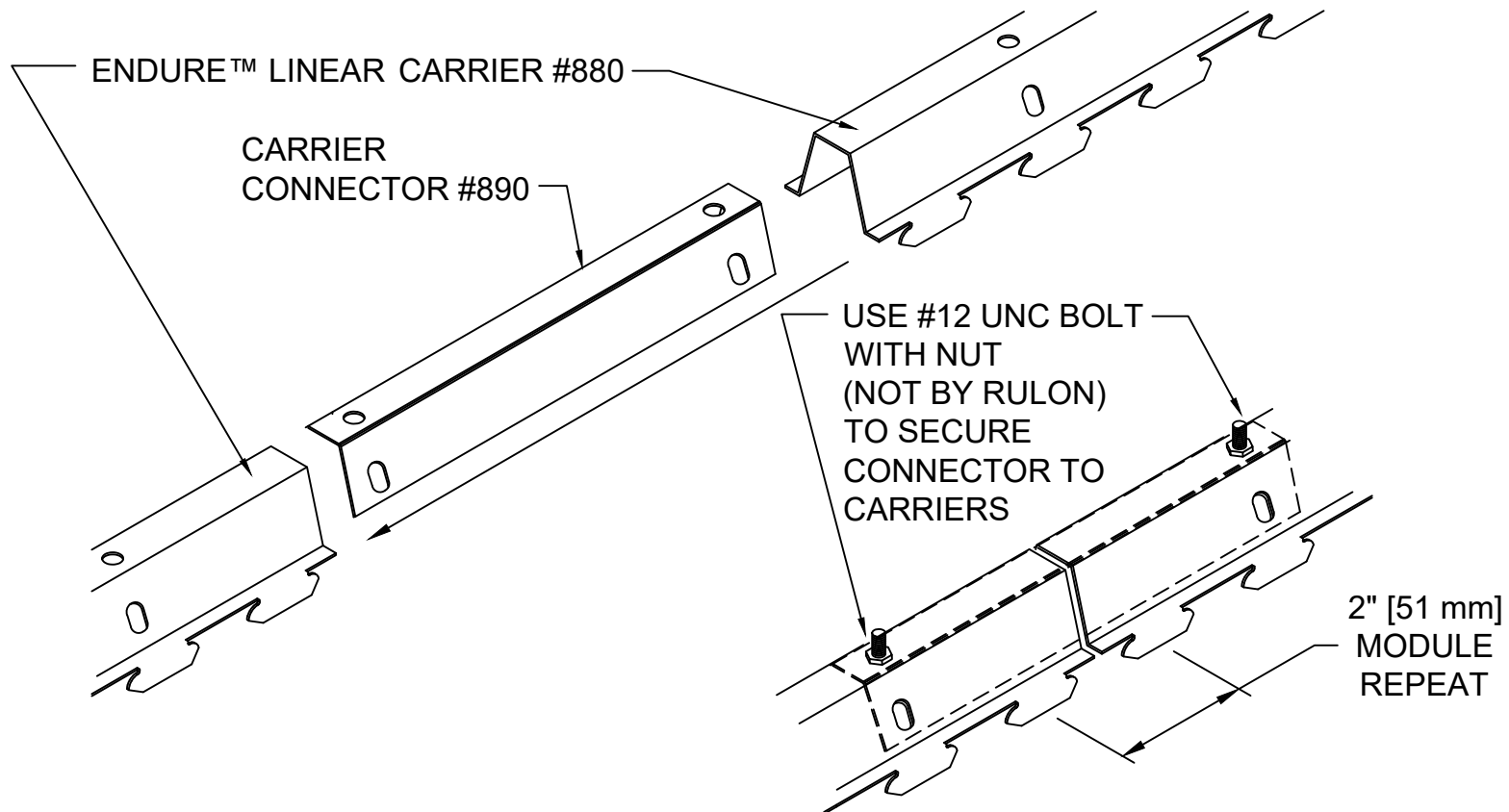

NOTE:  
 CARRIER CONNECTOR IS FOR  
 ALIGNMENT ONLY. SUPPORT  
 CARRIER AS NEEDED NEAR SPLICE.



RULON TIP

INSTALLATION TIP:  
 CARRIER CONNECTOR IS DESIGNED TO  
 BE POSITIONED INSIDE (AS SHOWN) OR  
 OUTSIDE OF THE CARRIER; ATTACHED  
 THROUGH HOLES IN TOP (AS SHOWN)  
 OR SIDES



RULON INTERNATIONAL  
 2000 Ring Way  
 St. Augustine, FL 32092

(904) 584-1400  
 info @ rulonco.com

www.rulonco.com

PROJECT:

ISSUE DATE:

DRAWN BY:

PROJECT NUMBER:

CAP

TITLE: **ENDURE™ LINEAR #890 Carrier  
 Connector**

REVISION DATE:

CHECKED BY:

DRAWING NUMBER:

MAR/14/2019

TR

PXX00003

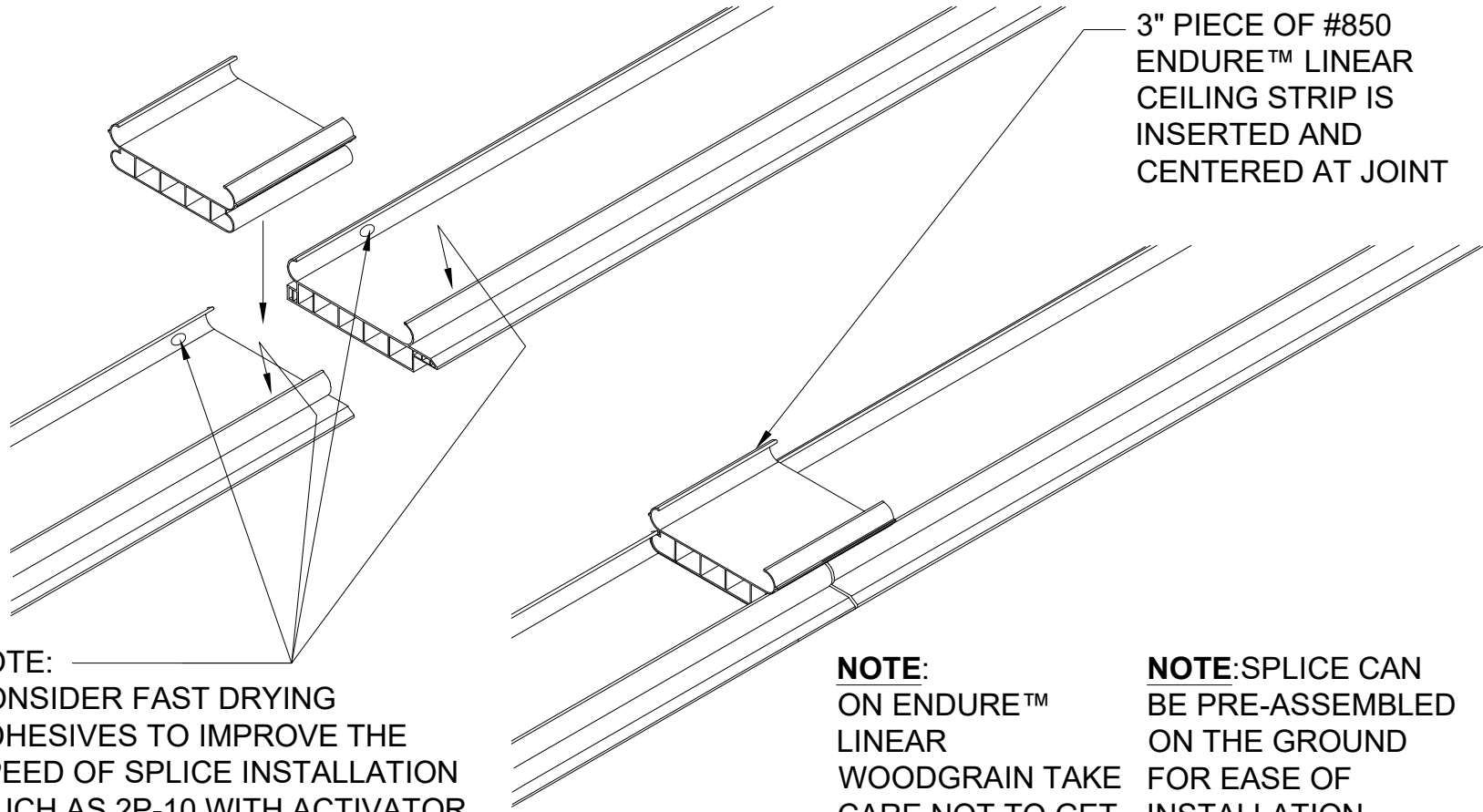

3" PIECE OF #850  
ENDURE™ LINEAR  
CEILING STRIP IS  
INSERTED AND  
CENTERED AT JOINT

**NOTE:**  
CONSIDER FAST DRYING  
ADHESIVES TO IMPROVE THE  
SPEED OF SPLICE INSTALLATION  
(SUCH AS 2P-10 WITH ACTIVATOR  
OR TITEBOND PVC TRIM ADHESIVE)

**NOTE:**  
ON ENDURE™  
LINEAR  
WOODGRAIN TAKE  
CARE NOT TO GET  
ADHESIVE ON  
WOODGRAIN FILM

**NOTE:** SPLICE CAN  
BE PRE-ASSEMBLED  
ON THE GROUND  
FOR EASE OF  
INSTALLATION



RULON INTERNATIONAL  
2000 Ring Way  
St. Augustine, FL 32092  
  
(904) 584-1400  
info @ rulonco.com  
  
www.rulonco.com

PROJECT:	ISSUE DATE:	DRAWN BY:	PROJECT NUMBER:
TITLE: ENDURE™ LINEAR #850S Splice Material	REVISION DATE: APR/24/2026	CAP CHECKED BY: MS/TR	DRAWING NUMBER: P8500004

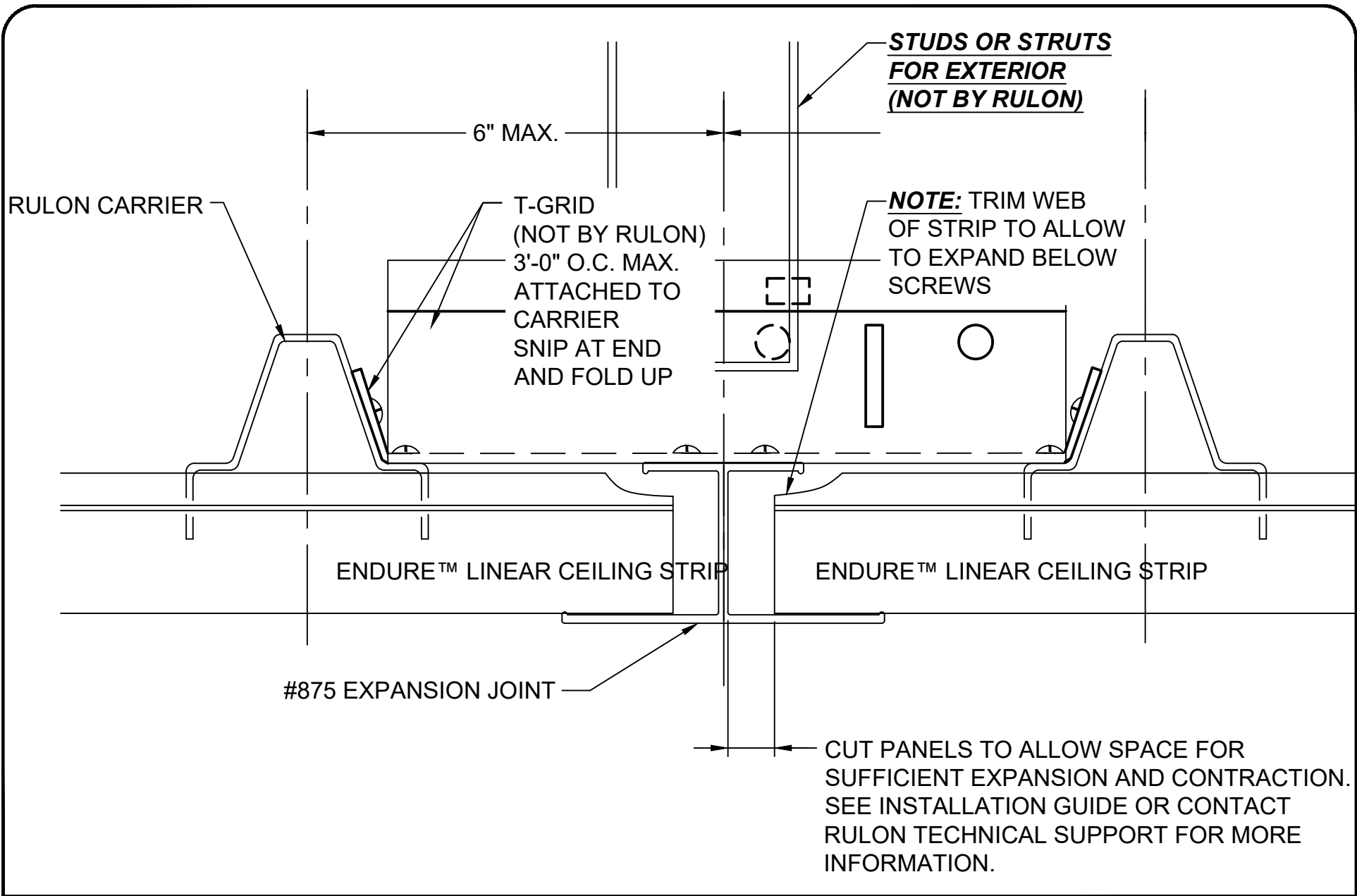

RULON INTERNATIONAL  
2000 Ring Way  
St. Augustine, FL 32092

(904) 584-1400  
info @ rulonco.com

www.rulonco.com

PROJECT:

TITLE: **ENDURE™ LINEAR #875**  
Expansion Joint Detail

ISSUE DATE:

REVISION DATE:  
OCT/02/2023

DRAWN BY:

CAP

CHECKED BY:

TR

PROJECT NUMBER:

DRAWING NUMBER:

P9000005

**CHANNEL STRUT CROSS-SECTION, TYPICAL**

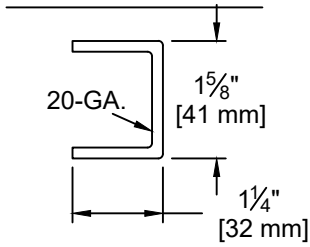

**#12 GA. HANGER WIRE CENTERS AS FOLLOWS:  
 INTERIOR: 4' O.C. MAX (STRUTS OPTIONAL)  
 EXTERIOR: 2' O.C. MAX (STRUTS REQUIRED)**

 **RULON TIP**  
 CONTACT RULON  
 ENGINEERING FOR  
 COASTAL  
 APPLICATIONS  
 (PROJECT-SPECIFIC)

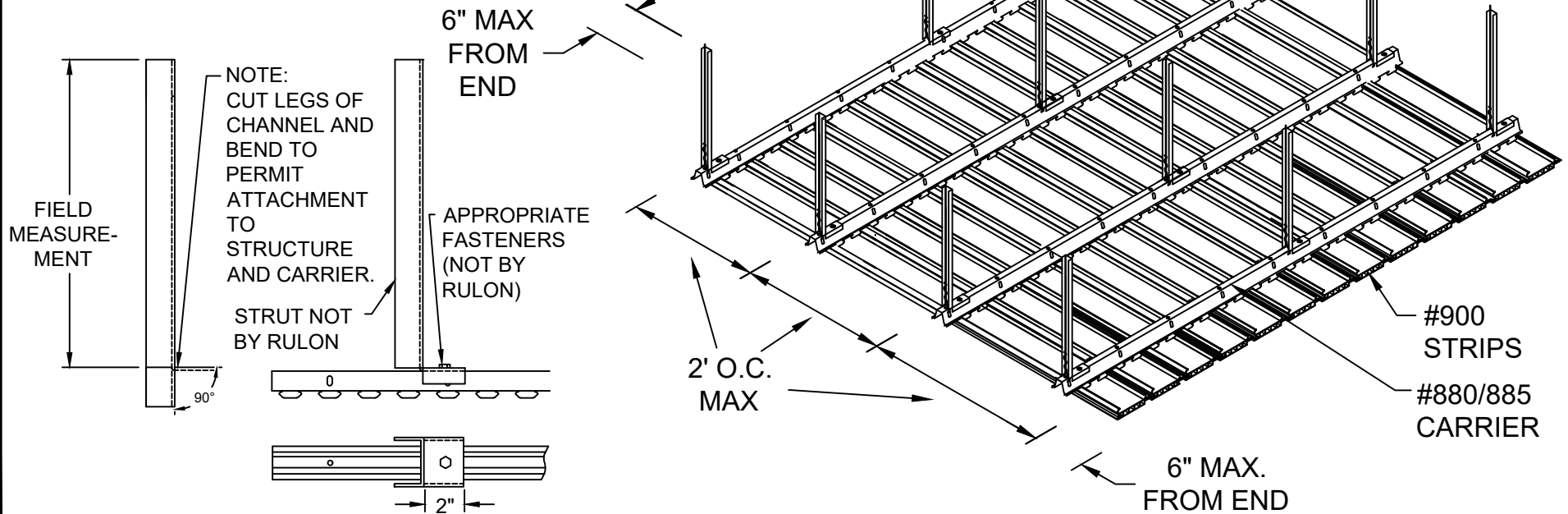

**TYPICAL STRUT**



RULON INTERNATIONAL  
 2000 Ring Way  
 St. Augustine, FL 32092

(904) 584-1400  
 info@rulonco.com

www.rulonco.com

PROJECT:

ISSUE DATE:

DRAWN BY:

PROJECT NUMBER:

CAP

TITLE: **ENDURE™ LINEAR 900**  
 Installation - Spacing

REVISION DATE:

CHECKED BY:

DRAWING NUMBER:

SEP/25/2025

CMP

P9000006

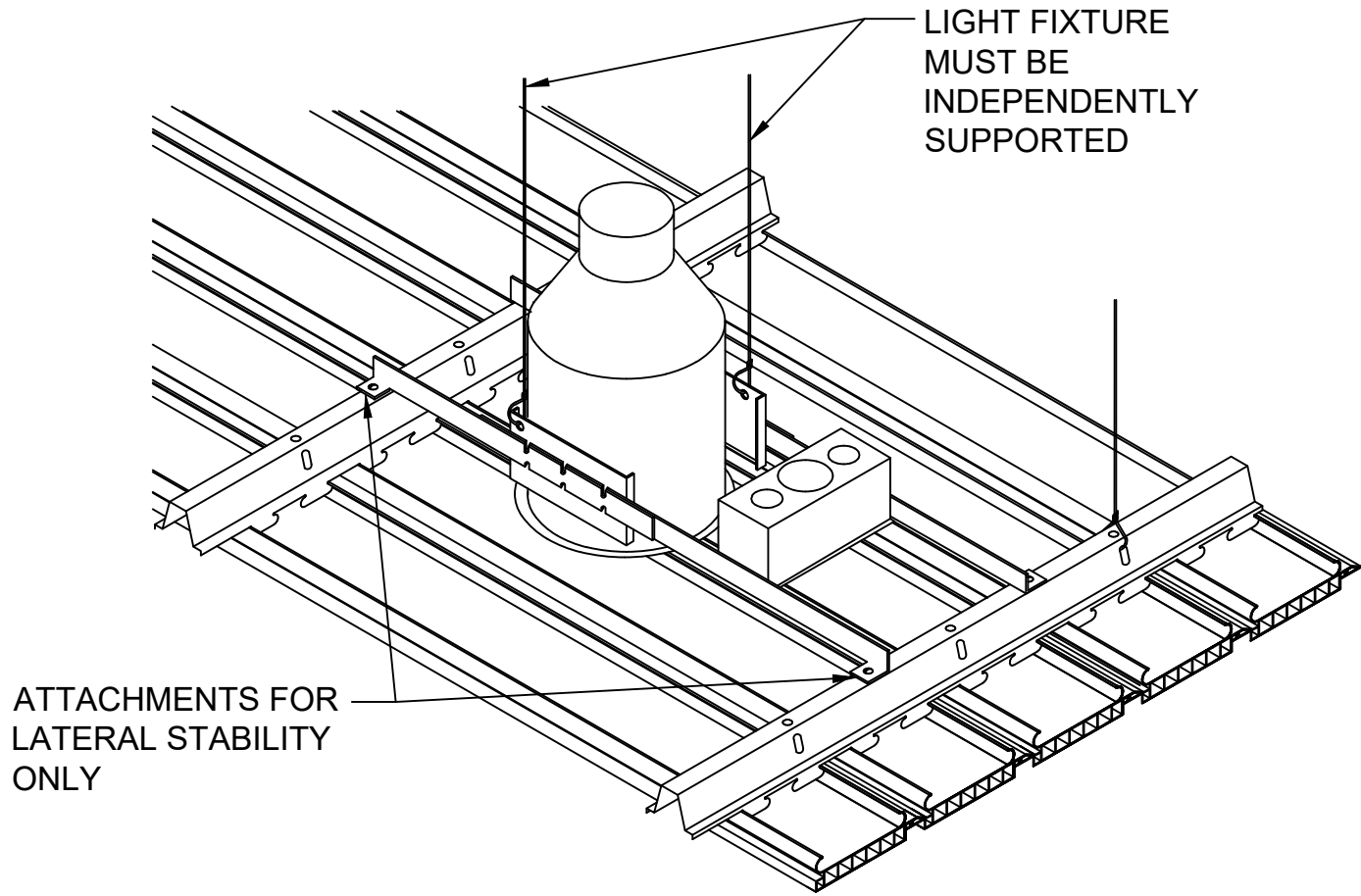

RULON INTERNATIONAL  
2000 Ring Way  
St. Augustine, FL 32092

(904) 584-1400  
info @ rulonco.com

www.rulonco.com

PROJECT:

TITLE: **ENDURE™ LINEAR Recessed  
Can Light Detail**

ISSUE DATE:

REVISION DATE:  
**JUN/23/2015**

DRAWN BY:

**CAP**

CHECKED BY:

**TR**

PROJECT NUMBER:

DRAWING NUMBER:

**P9000008**

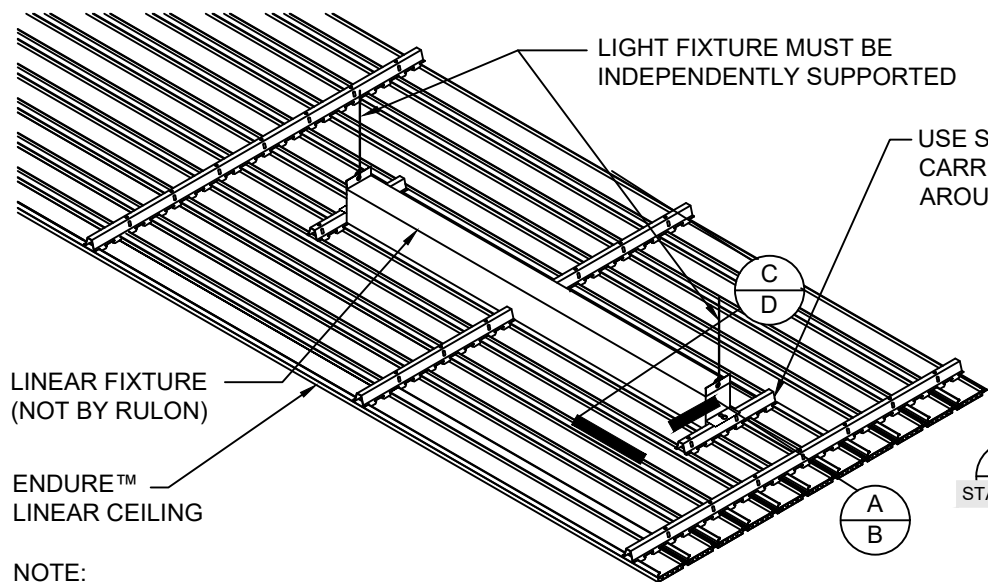

NOTE:  
CEILING CARRIER SUPPORTS  
OMITTED FOR CLARITY

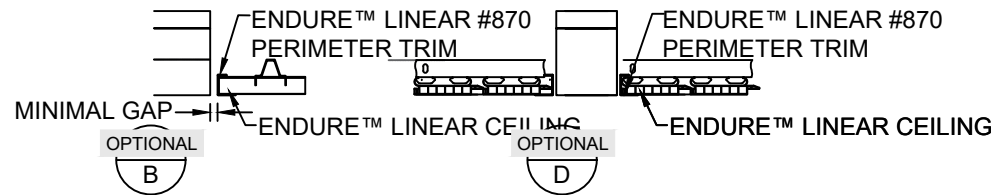
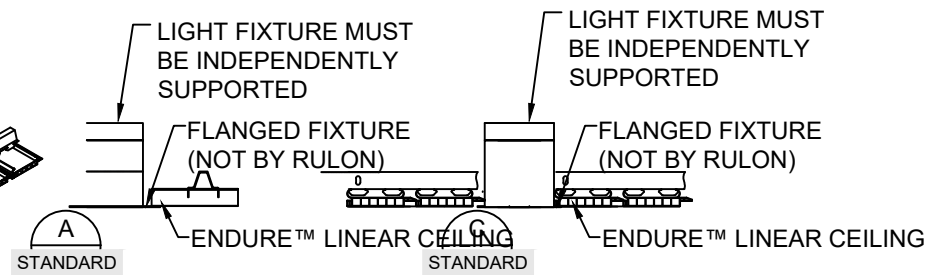

RULON INTERNATIONAL  
2000 Ring Way  
St. Augustine, FL 32092

(904) 584-1400  
info @ rulonco.com

www.rulonco.com

PROJECT:

TITLE: **ENDURE™ with Linear Light  
Fixture**

ISSUE DATE:

REVISION DATE:  
**JAN/31/2023**

DRAWN BY:

**CAP**

CHECKED BY:

**CRD**

PROJECT NUMBER:

DRAWING NUMBER:

**P9000009**

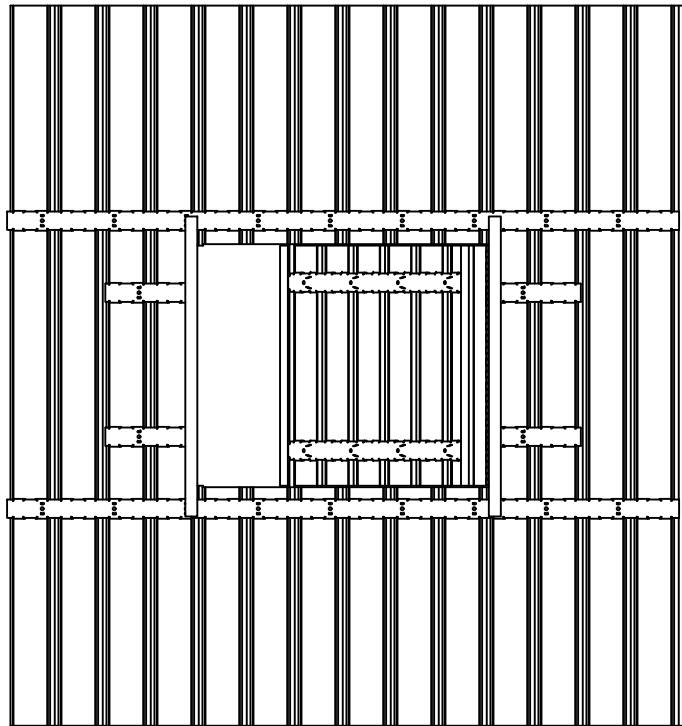

**PLAN VIEW**  
(ACCESS PANEL PARTIALLY OPEN)

SEE HINGE DETAIL BELOW  
SEE LATCH DETAIL BELOW

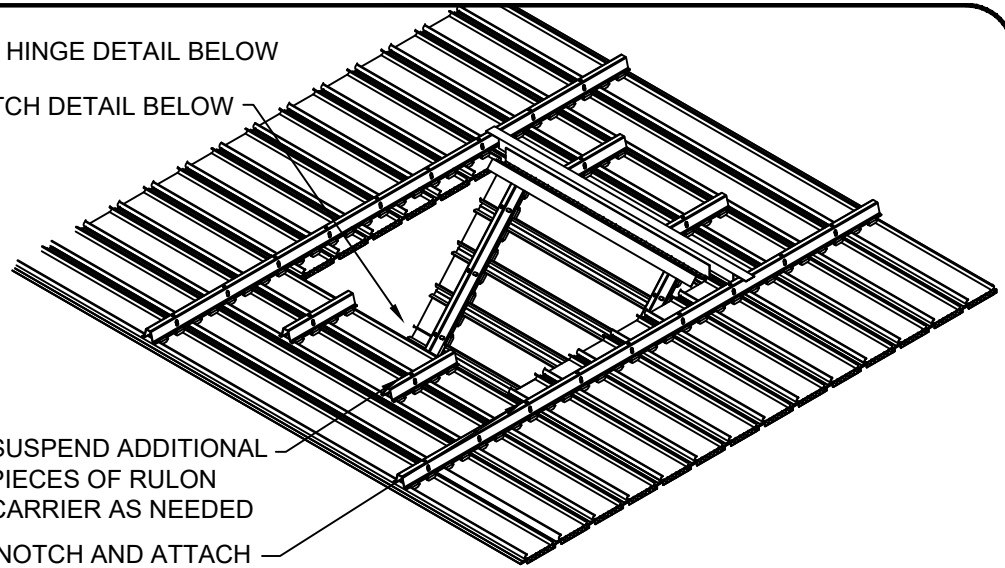

SUSPEND ADDITIONAL  
PIECES OF RULON  
CARRIER AS NEEDED  
FIELD-NOTCH AND ATTACH  
1" [25 mm] L-ANGLE  
(NOT BY RULON)

**NOM. 2' X 2' ACCESS PANEL SHOWN**  
(SIZE VARIES PER PROJECT)

1" [25 mm] L-ANGLE ATTACHED TO ENDURE™ LINEAR CARRIER  
WITH MACHINE SCREWS AND NUTS (NOT BY RULON)  
ATTACH HINGE TO L-ANGLE (NOT BY RULON)

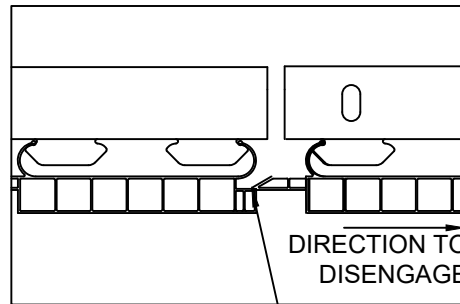

**LATCH DETAIL**  
(SHOWN CLOSED)

DIRECTION TO  
DISENGAGE

INTERFERENCE  
FIT - APPLY  
PRESSURE TO  
DISENGAGE

1½" [38 mm] DOOR  
HINGE, ATTACHED  
TO L-ANGLE WITH  
MACHINE SCREWS  
AND NUTS  
(NOT BY RULON)

REMOVE INTEGRAL  
SPACER IN FIELD  
WITH ROUTER  
(ENDURE™ LINEAR  
900 ONLY)

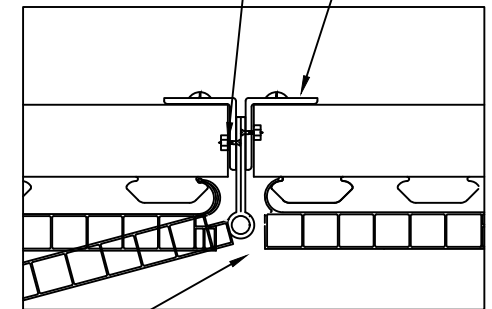

**HINGE DETAIL**  
(SHOWN CLOSED)



RULON INTERNATIONAL  
2000 Ring Way  
St. Augustine, FL 32092

(904) 584-1400  
info @ rulonco.com

www.rulonco.com

PROJECT:

TITLE: **ENDURE™ 900 Access Panel  
Detail**

ISSUE DATE:

REVISION DATE:  
**OCT/25/2024**

DRAWN BY:

**CAP**

CHECKED BY:

**TR**

PROJECT NUMBER:

DRAWING NUMBER:

**P9000010**

SHIM UNDER STUDS/STRUCTURE WHERE NECESSARY TO LEVEL THE CARRIERS

METAL STUDS OR STRUCTURE (NOT BY RULON)

METAL STUD

SHIM

#880 CARRIER

#880 CARRIER

ATTACH #880 CARRIER TO METAL STUDS /STRUCTURE USING SCREWS 2' ON CENTER\*\* (NOT BY RULON)

\*\*WHEN ATTACHING TO PLYWOOD SHEATHING/FURRING USE SCREWS 1' O.C. TYPICAL



RULON INTERNATIONAL  
2000 Ring Way  
St. Augustine, FL 32092

(904) 584-1400  
info @ rulonco.com

www.rulonco.com

PROJECT:

TITLE: **ENDURE™ LINEAR Direct Mount Detail**

ISSUE DATE:

REVISION DATE:  
**DEC/17/2025**

DRAWN BY:

**CAP**

CHECKED BY:

**CMP**

PROJECT NUMBER:

DRAWING NUMBER:

**P8X00012**