



RULON INTERNATIONAL

ALURATONE DATA SHEET

SYSTEM: ALURATONE

PROFILE: 900
(U-GROOVED)

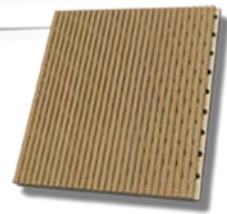

Overview

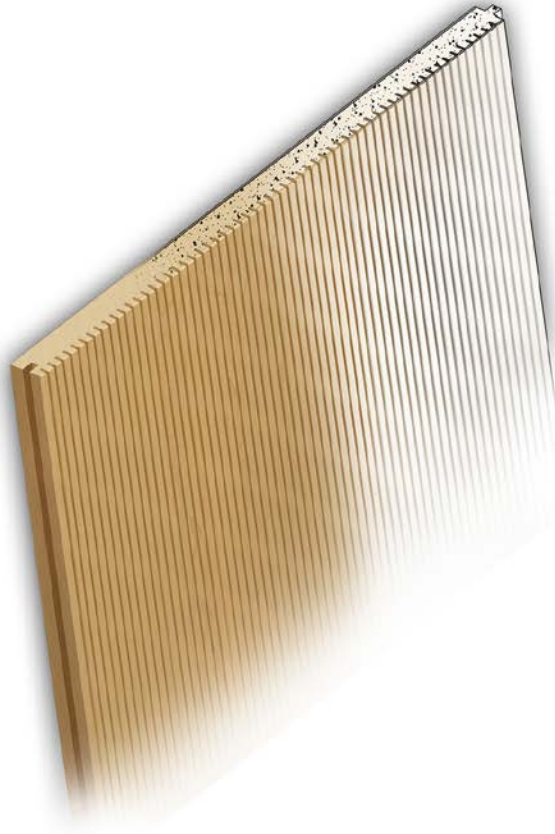

SYSTEM

Aluratone acoustical wood ceiling and wall panels combine the warmth and beauty of wood with effective acoustical performance. Assembled with an acoustic nonwoven backer, these panels provide excellent sound attenuation and are typically found in high-occupancy areas. Aluratone 900 panels are designed with u-grooves in the face to allow for excellent sound absorption. Aluratone is only available in veneer.



RULON INTERNATIONAL

ALURATONE DATA SHEET

SYSTEM: ALURATONE

PROFILE: 900
(U-GROOVED)

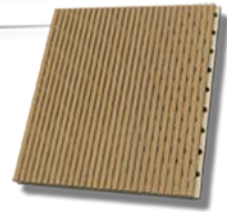

Technical Data

VARIABLES



ENGINEERING CONSIDERATIONS

Aluratone 900 is manufactured at Rulon's plant in St. Augustine, FL. All shop drawings and coordination details are produced by Rulon's engineering staff.



ACCESSIBILITY

Aluratone 900 is a fully-accessible Rulon ceiling or wall system unless direct-screw attached. Panels are suspended from grid by **C-Hangers^A** or **Torsion Springs & Saddle Clips^B**. Ceiling panels can also be manufactured with a variety of edge conditions including tegular, lay-in, and side slot. Wall panels are attached with **Z-Clips^E**.



ACOUSTICS

Aluratone 900 is manufactured with an **Acoustic Nonwoven Backer^C**, a sound-absorbing fabric adhered to the back of the panel. The acoustical performance of all Aluratone products is dependent on project design, application, mounting method, and additional sound absorbent material. Acoustical performance can be achieved up to NRC-0.90. For general reference, please see the open area calculation table in the following section.



SUSTAINABILITY

Aluratone 900 may contribute as required to the following LEED v4 credits: **MR BPD&O – Sourcing of Raw Materials**, **MR BPD&O – Material Ingredients**, **EQ Low-Emitting Materials**, **EQ Minimum Acoustic Performance**



FIRE PERFORMANCE

Aluratone 900 can be treated to meet **Class A** requirements as per ASTM E-84. Veneers are applied to an FR (Fire Rated) core (typically MDF or Particleboard).



SEISMIC

Aluratone 900 meets seismic code compliance via direct screw attachment to heavy duty grid. Local code requirements should be consulted in order to determine additional requirements.



INTEGRATIONS

Aluratone 900 can be easily trimmed in-field to accommodate MEP integrations. Touch-up finish and edgbanding is supplied to veneer and seal cut sections. In-factory cutouts can be achieved with dedicated coordination and in conjunction with the **Integrated Lighting^D** program at Rulon.



GENERAL COSTING

Aluratone 900 is typically a moderately priced system depending on the material and manufacturing requirements. Aluratone 900 qualifies as **\$\$\$** on the general costing scale. Local reps should be contacted in order to obtain a project-specific budget.



RULON INTERNATIONAL

ALURATONE DATA SHEET

SYSTEM: ALURATONE

PROFILE: 900
(U-GROOVED)

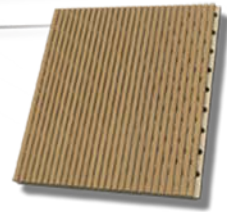

Specification

COMPONENTS

HANGERS

#12- gauge wire hangers (contractor-supplied).

SUSPENSION SYSTEM

Ceiling Panels should be suspended using standard 15/16" [24 mm] heavy duty grid (contractor-supplied). Tegular or Lay-in ceilings may be suspended using standard 9/16" [14 mm] medium duty or 15/16" [24 mm] heavy duty grid (contractor-supplied). Mains for 15/16" [24 mm] heavy duty grid shall be a max of 2' [610 mm] on center.

ATTACHMENT

Ceiling Panels may be suspended from grid using **C-Hangers^A** (see drawing AXXX0011) or **Torsion Springs & Saddle Clips^B** (see drawing AXXX0012). Panels may also be directly screwed to grid from above (see drawing AXXX0015). Wall Panels may be attached by **Z-Clips^E** (see drawing AXXX0013). When supplied with tongue and groove, panels may be direct nailed through the tongue into furring supplied by the contractor (see drawing D-272). Ceiling panels can also be manufactured with a variety of edge conditions including tegular, lay-in, and side slot (see drawing AXXX0016).

SIZES

Panels are made from premium grade veneers adhered to a wood substrate (typically MDF or Particleboard). Face veneer is finished to customer requirements. Panels may be manufactured in sizes up to 4' [1219 mm] by 10' [3048 mm]. Grain direction typically follows the length of the panel.

FACE PROFILES

Aluratone 900 is manufactured with a 2mm (0.079") wide 'u-shaped' groove on 10mm (0.394") centers. The substrate is **Back-Bored^F** to allow for increased open area and greater sound attenuation while minimizing visible face machining.

OPEN AREA & SOUND ATTENUATION

Acoustical performance of Aluratone 900 is dependent on the project design, application, mounting method and if additional sound absorbent material incorporated within the system. For general reference, please see the open area calculation table below. Consult Rulon's technical department for specific data based on project requirements.



RULON INTERNATIONAL

ALURATONE DATA SHEET

SYSTEM: ALURATONE

PROFILE: 900
(U-GROOVED)

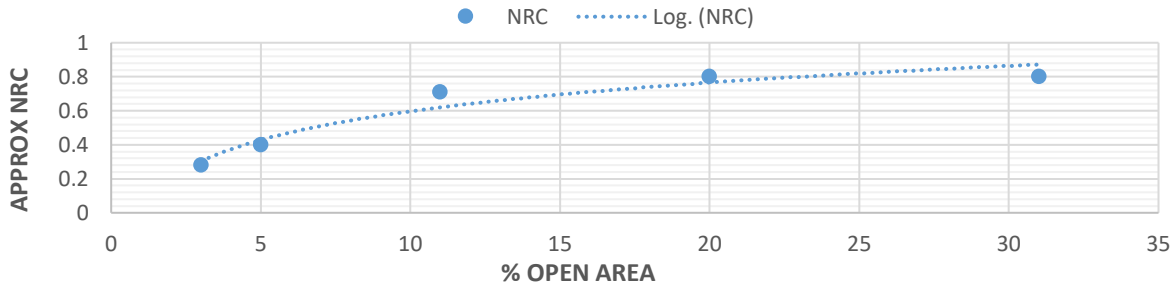
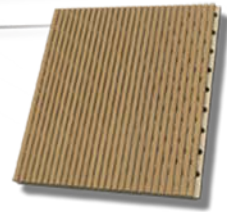

PERIMETER TRIMS

Ceiling termination at a wall or soffit is accomplished using various trims (for example, see drawing D-120).

WOOD SELECTIONS

WOOD SPECIES

Aluratone 900 may be specified in a variety of veneer species. Standard wood species are: Ash, Maple, Red Oak, White Oak, Anegre, Beech, Bamboo, and Cherry. Premium veneers and non-wood laminates are available.

TEXTURES

The standard surface texture is smooth-sawn. Faces are sanded.

FINISHING & COMPONENTS

WOOD FINISHES

The standard finish is satin clear. Custom stains, opaque or semi-transparent colors are also available. All finishes are water based, low VOC-emitting, and do not contain solvents.

SHIPPING & STORAGE

SHIPPING

Aluratone 900 panels are shipped on skids in shrink wrap packaging. Finished surfaces are facing one another with slip sheets between to prevent marring.

STORAGE

Aluratone 900 shall be stored flat and level, in a fully enclosed space. For a minimum of seventy-two (72) hours immediately prior to ceiling installation, the packaging shall be opened and the panels shall be stored in the room in which they will be installed. The temperature and humidity of the room shall closely approximate those conditions that will exist when the building is occupied. Panels must be stored off the floor.



RULON INTERNATIONAL

ALURATONE DATA SHEET

SYSTEM: ALURATONE

PROFILE: 900
(U-GROOVED)

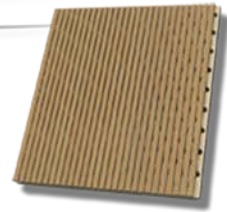

Typical Details

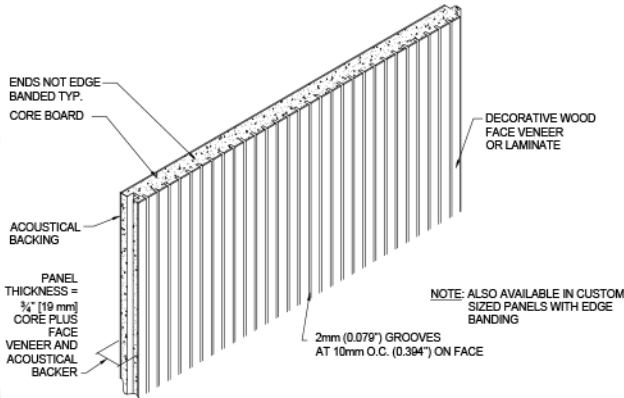

ISOMETRIC VIEW

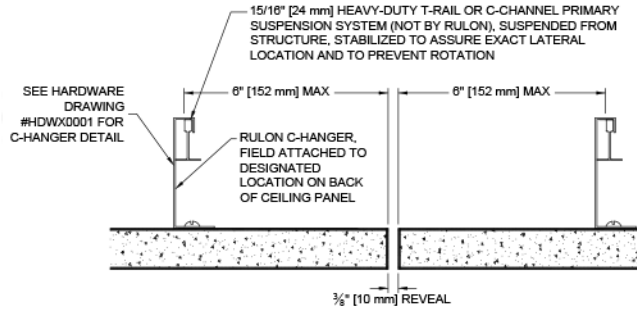

C-HANGERS

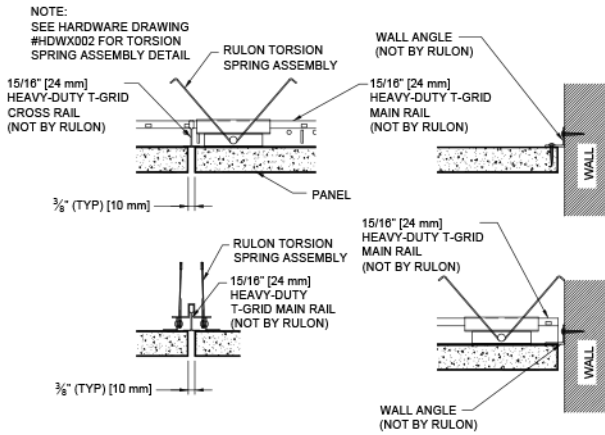

TORSION SPRINGS

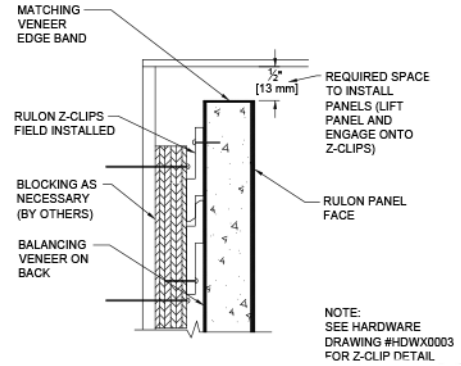

Z-CLIPS



RULON INTERNATIONAL

ALURATONE DATA SHEET

SYSTEM: ALURATONE

PROFILE: 900
(U-GROOVED)

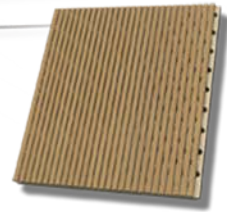

Notes

- ^A C-Hangers are suspension hangers that are direct-screwed to the panel and hang over the heavy duty-grid. The clips are made of spring-steel with phosphate pre-treatment and corrosion-resistant coating.
- ^B Torsion Springs and Saddle Clips are two parts of a suspension system in which the torsion spring is direct-screwed to the panel and compressed to attach to the saddle clip that is fitted over the heavy duty-grid. The clips are made of spring-steel with phosphate pre-treatment and corrosion-resistant coating.
- ^C Acoustic Nonwoven Backers are thin, sound-absorbing fabrics that can be applied to a substrate in order to increase sound attenuation.
- ^D The Integrated Lighting program at Rulon is in partnership with GE Lighting and is an effort to coordinate MEPs more effectively and provide for a more streamlined process of integration. In practice, this effort begins with factory cutouts to accommodate light fixtures.
- ^E Z-Clips are male/female aluminum attachment clips, similar to a French cleat but with a thinner profile, used to hang wood wall panels on furring strips.
- ^F Back-boring is a machining process by which a large diameter hole is bored from the back of a panel (typically 50%-75% of the substrate depth) concentric with a smaller diameter hole, groove, or other machined pattern on the front of a panel. This process allows for increased open area and greater sound attenuation while minimizing visible machining on the face of a panel.
- ^G Not used.
- ^H Not used.
- ^I Not used.
- ^J Not used.
- ^K Not used.
- ^L Not used.